

WSS

World Super Series

Technical Catalogue

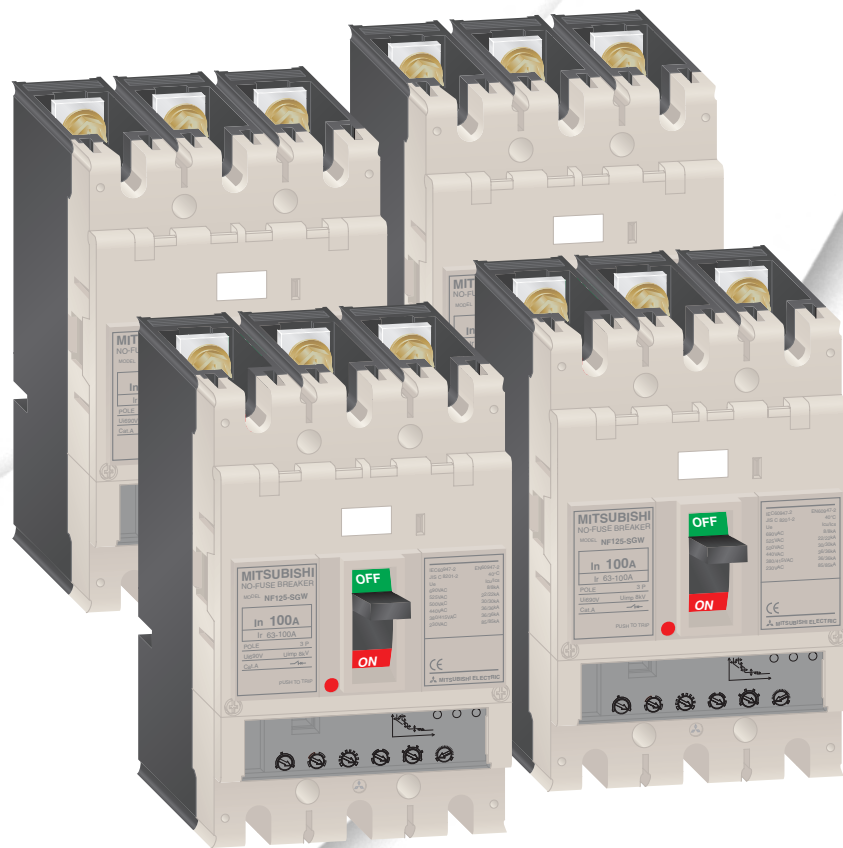

Moulded-Case Circuit Breakers /// Disconnectors ///
NF-S /// NF-H /// NF-R /// NF-U ///

Further Publications within the Factory Automation Range

Technical catalogue System Q

Product catalogues for programmable logic controllers and accessories for the further MELSEC PLC series

Technical catalogue Alpha and FX family

Product catalogues for programmable logic controllers and accessories for the Alpha and FX families

Technical catalogue Frequency inverters

Product catalogue for frequency inverters and accessories

Technical catalogues MELSERVO and Motion Controllers

Product catalogues for servo motors and amplifiers of the MR-J2S Series and Motion Controllers with SSCNET

Technical catalogue Robots

Product catalogue for MELFA industrial robots and accessories

More information?

This technical catalogue is designed to give an overview of the extensive range of moulded-cas circuit breakers of the World Super Series and related accessories. If you cannot find the information you require in this catalogue, there are a number of ways you can get further details on configuration and technical issues, pricing and availability.

For technical issues visit the www.mitsubishi-automation.com website.

Our website provides a simple and fast way of accessing further technical data and up to the minute details on our products and services. Manuals and catalogues are available in several different languages and can be downloaded for free.

For technical, configuration, pricing and availability issues contact our distributors and partners.

Mitsubishi partners and distributors are only too happy to help answer your technical questions or help with configuration building. For a list of Mitsubishi partners please see the back of this catalogue or alternatively take a look at the "contact us" section of our website.

About this technical catalogue

This catalogue is a guide to the range of products available. For detailed configuration rules, system building, installation and configuration the associated product manuals must be read. You must satisfy yourself that any system you design with the products in this catalogue is fit for purpose, meets your requires and conforms to the product configuration rules as defined in the product manuals.

Specifications are subject to change without notice. All trademarks acknowledged.

1 Introduction and Configuration

◆ Circuit Breakers	4
◆ Electronic Breakers	6
◆ Calculation and Selection Software MELSHORT2	7
◆ Product Skeleton of Accessories	8
◆ Model Overview and Specifications	10

2 Circuit Breakers

◆ Specifications of Moulded-Case Circuit Breakers	12
◆ Specifications of Switches / Disconnectors	20
◆ Order information of Circuit Breakers	22

3 Internal Accessories

◆ Introduction and Installation	24
◆ Alarm Switch and Auxiliary Switch	26
◆ Shunt Trip Device	28
◆ Undervoltage Tripping Device	30

4 External Accessories

◆ Accessories for Connection and Installation	35
◆ Operating Handles	36
◆ Handle Lock Devices	37
◆ Electrically Operated Breakers	38
◆ Terminal Covers	40
◆ Mechanical Interlocks, Insulating Barriers, Rail Adapter	41
◆ Tester for Electronic Breakers	42

World Super Series WSS – The Extensive Breaker Series from Mitsubishi Electric

The circuits of the Mitsubishi breaker series are amongst the smallest compact circuit breakers in the world with electronic overload indication of this kind.

The system is based, among other things, on the well-known and proven microprocessor technology.

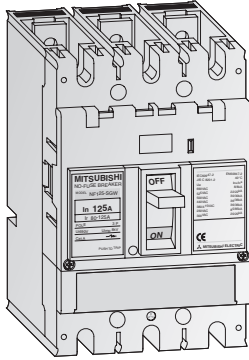

NF125-SGW RT, 3p

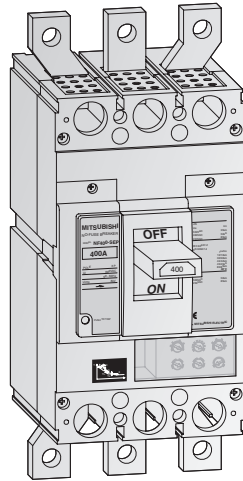

NF400-SEW, 3p

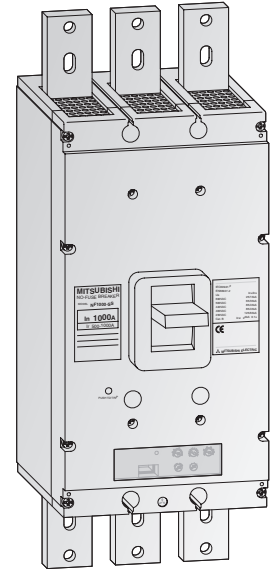

NF1000-SEW, 3p

WSS – World Super Series

The new WSS breaker series meets national and international protection ratings according to VDE, EN, and IEC standards for industrial applications as well as for extended shipping demands.

The new tripping technology guarantees a high reliability and highest protection.

- 16 to 250 A in one model size (3- and 4-pole)
- interchangeable relay unit (thermal type or electronic type)
- available in fixed and plug-in versions
- breaking capacity
Ics = 100 % Icu, up to 690 V

The proven Progressive Super Series features technical know-how and the microprocessor technology tried and tested in longstanding experience.

The fully enclosed circuit breakers provide an increased safety and at the same time decreased switching times.

- 400 to 800 A
- 2 model sizes (3- and 4-pole)
- electronic trip system
- available in fixed and plug-in versions
- additional disconnectors available

The proven standard series for a high breaking performance providing an optimum protection for transformer and generator feed in, and output breakers.

Circuit breakers can be used as section or disconnecting switch.

- 1000 to 1600 A
- 1 model size (3- and 4-pole)
- electronic trip system
- available in fixed and plug-in versions

Intelligent Breaking Technology for Your Safety

With its innovative breaking technology all Mitsubishi breakers offer greater safety and even faster circuit-breaking speed through the use of the latest switch-off technology and innovative engineering, with a newly developed electronic trip relay.

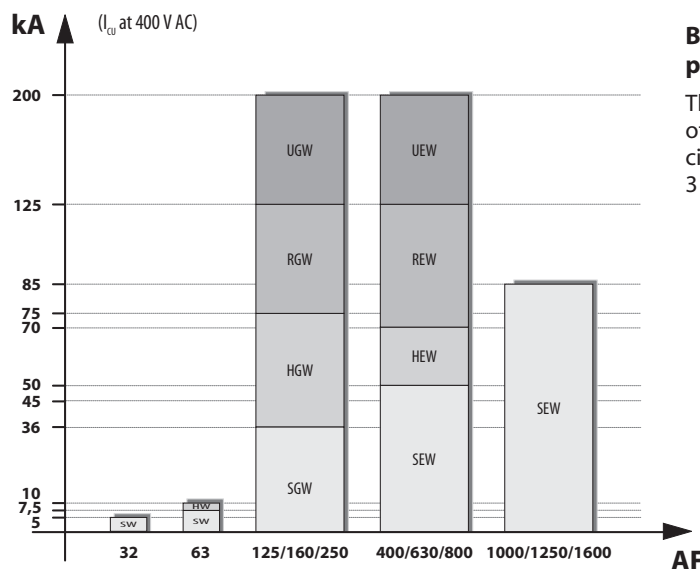

Breaking performance

The complete range of moulded case circuit breakers from 3 to 1600 A.

Outline

New breaking technology

With its new breaking technology the circuit breakers offer greater safety and even faster circuit-breaking speed through the use of the latest switch-off

technology and innovative engineering, with a newly developed electronic trip relay.

Arc-extinguishing device

Mitsubishi MCCBs feature excellent arc-extinguishing performance by virtue of the optimum combination of grid gap, shape, and material.

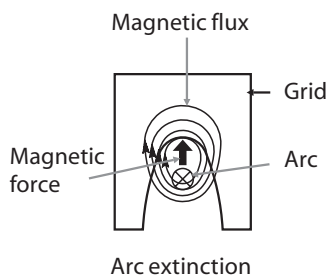

Arc runner

The arc is instantaneously transferred to the arc-extinguishing chamber (see the figure above) by the arc runner, which reduces damage to contacts and improves interrupting performance.

Trip button (push to trip)

Enables tripping mechanically from outside, for confirming the operation of the accessory switches and the manual resetting function.

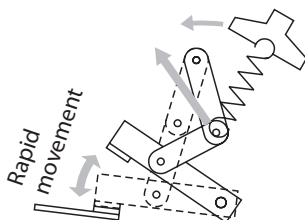

Switching mechanism

The contacts open and close rapidly, regardless of the moving speed of the handle, minimizing contact wear and ensuring safety.

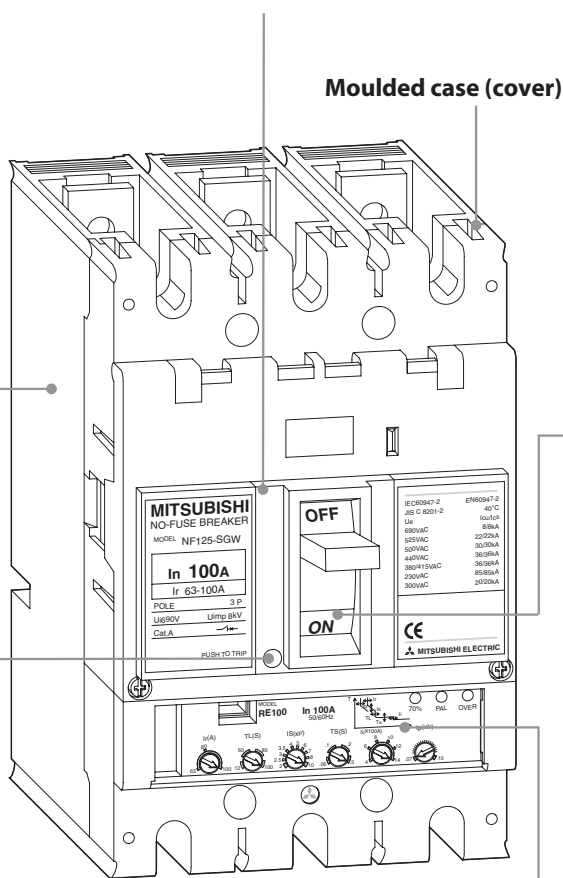

Handle

- **Trip indication**
The automatically tripped condition is indicated by the handle in the center position between ON and OFF; the yellow or white line cannot be seen in this position. The figure shows the handle in tripped position.
- **Resetting**
Resetting after tripping is performed by first moving the handle OFF position to engage the mechanism, then returning the handle to ON to reclose the circuit.
- **Trip-Free**
Even if the handle is held at ON, the breaker will trip if an overcurrent flows.
- **Contact on Mechanism**
Even in the worst case in which welding occurs owing to an overcurrent, the breaker will trip and the handle will maintain to ON, indicating the energizing state.

Type NF125-SGW construction

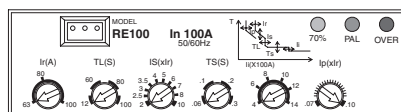

Trip relay with control dials

Adjustable thermal trip current value

The setting can be changed by simply turning the control dials, providing the optimum characteristics for particular road conditions.

A Microcomputer and Mitsubishi's Original IC fulfill a New High Level of Safety

Safer and more reliable power

Electronic device loads, such as inverters, distort the current waveform. Mitsubishi's electronic breakers use a digital detector to measure the current's effective value and minimize overload tripping errors. This enables precise protection of the circuit.

Alarm function monitors and anticipates interruptions

Our electronic moulded-case circuit breakers feature a pre-alarm system as standard. The pre-alarm outputs an alarm before the circuit breaker trip is activated. When the load current exceeds the set pre-alarm current, it outputs a pre-alarm signal (from a solid-state relay) and lights the LED.

The pre-alarm module (with contact output) is optional with electronic moulded-case and earth-leakage circuit breakers.

Improved protection against fluctuations in the load current

Our standard electronic trip relay offers a number of outstanding benefits. The user has a choice of six different parameters as tripping characteristics with the multiple coordinated protection method. Better protection can be obtained between the high-voltage fuse, OCR and the low voltage fuse.

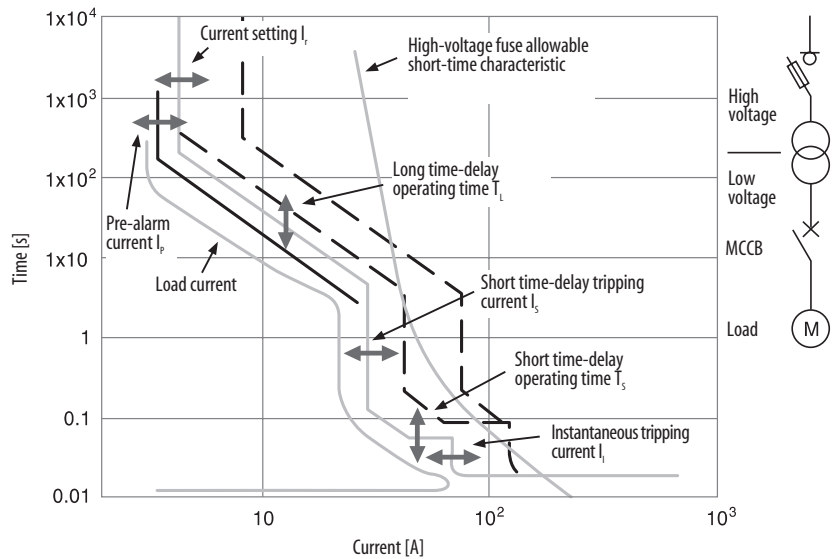

Coordinated protection from multiple tripping characteristics

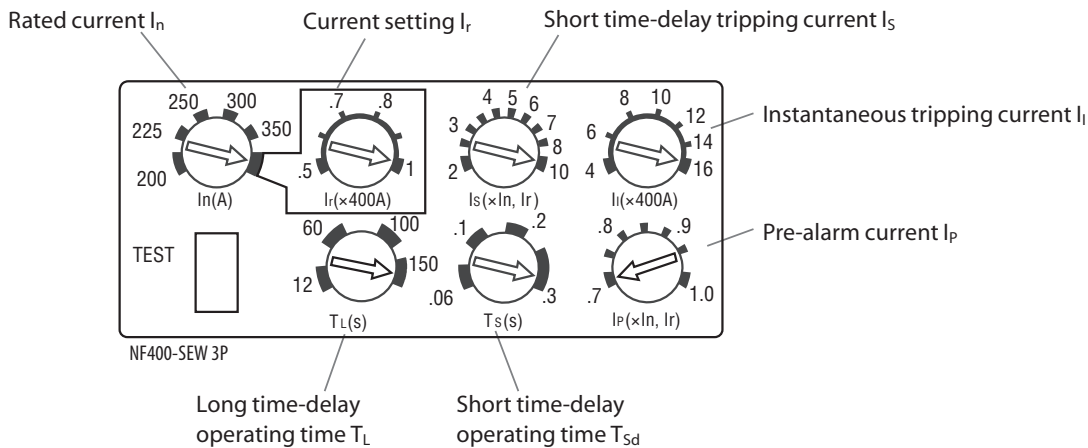

Portable tester facilitates checking and maintenance

The separately sold portable tester allows the user to check the four characteristics:

- 1. Long-delay tripping
- 2. Short-delay tripping
- 3. Instantaneous tripping
- 4. Pre-alarm characteristics

LEDs for load current, pre-alarm and over-current show the operating status.

Overload protection and safety

The neutral-pole overload protection circuit is standard with 4-wire electronic moulded-case devices. It prevents burn-out when the neutral-pole's load current is greater than the voltage pole in a 3-phase 4 wire circuit which is prone to distorted third-harmonic current flows.

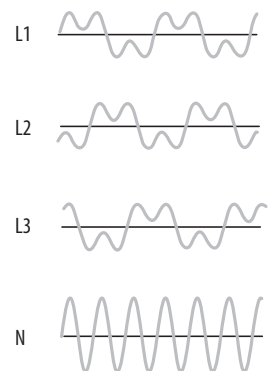

■ Calculation and Selection Software MELSHORT2

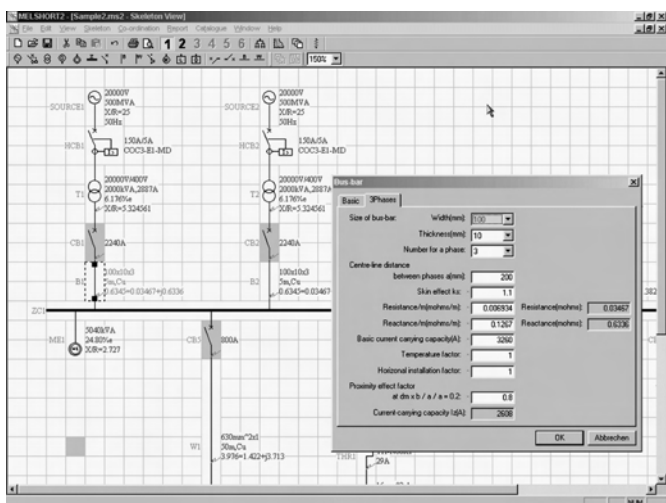

Circuit diagram of the network to be calculated, with input field

MELSHORT2 – The New Calculation Software for Low-Voltage Switchgears

MELSHORT2 is a software package that provides all the functions needed for planning and dimensioning switchgear systems. Increasingly demanding technical specifications and accountability regulations are making switchgear configuration much more critical than it used to be. In the past, software for calculating and dimensioning switchgear was helpful – nowadays it's absolutely essential.

Mitsubishi Electric's MELSHORT2 is a complete software package that provides all the functions needed for successful switchgear system configuration and layout. It supports all modern international electrical engineering standards and shines with simple and reliable operation.

The program calculates the short-circuit levels and currents at all necessary points for all switchgear components, including the power supply transformer and circuit breakers, the emergency generators, the individual motor and capacitor group branch circuits and all the other power distribution circuits, down to the last circuit breaker. This makes it possible to select the ideal breaker for every task, for optimum performance and cost-efficiency.

MELSHORT2 has a comprehensive range of powerful, easy-to-use functions, including:

- Selective shutdown
- Backup protection
- Coordination with the main power supply systems
- Allowance for the start-up currents of electric motors

These functions make it possible to optimise the configuration of your switchgear equipment for the specific requirements of your applications.

The calculated results, the hardware model suggestions and the wiring diagram with all the relevant values can be processed and used as documentation for the switchgear installation. Another welcome extra is the free Internet update service.

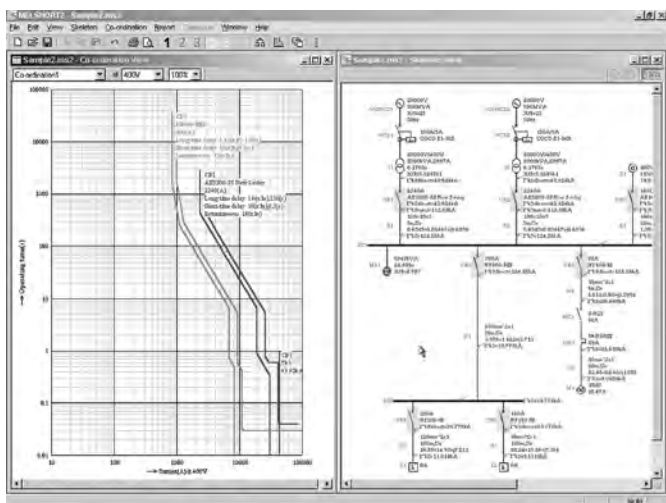

Display of the trip curves of a circuit breaker in the network

Specifications	MELSHORT2
Operating system	MS Windows 95/98/NT4.0/2000
Disk type	CD-ROM
Art. no.	129115

Product Skeleton of Accessories

MITSUBISHI ELECTRIC offers a wide range of accessories for the Moulded-case circuit breakers and Disconnectors to serve almost all variations of applications. Detailed information on request.

1 INTRODUCTION AND CONFIGURATION

1	Circuit Breaker	see page 12
2	Relay unit RT (Thermal type)	on request
3	Relay unit RE (Electronic type)	on request
4	Solderless (Box) terminals	see page 35
5	Rear connection studs	see page 35
6	Insulating barriers (BA-F)	see page 41
7	Small terminal covers (TC-S)	see page 40
8	Large terminal covers (TC-L)	see page 40
9	Rear terminal covers (BTC)	see page 40
10	Plug-in base (PM)	see page 35
11	Connections for Plug-in	see page 35
12	Mechanical interlock (MI)	see page 41
13	OFF Lock with 3 padlocks (HL)	see page 37
14	Handle lock device (LC, HLF, HLN, HLS)	see page 37
15	Variable-depth operating handle, V type	see page 36
16	Rotary operating handle, R type	see page 36
17	Electrical operating device (MDS)	see page 39
18	Alarm and Auxiliary switches (AL, AX)	see page 26
19	Under voltage trip device (UVT)	see page 30
20	Shunt trip device (SHT)	see page 28

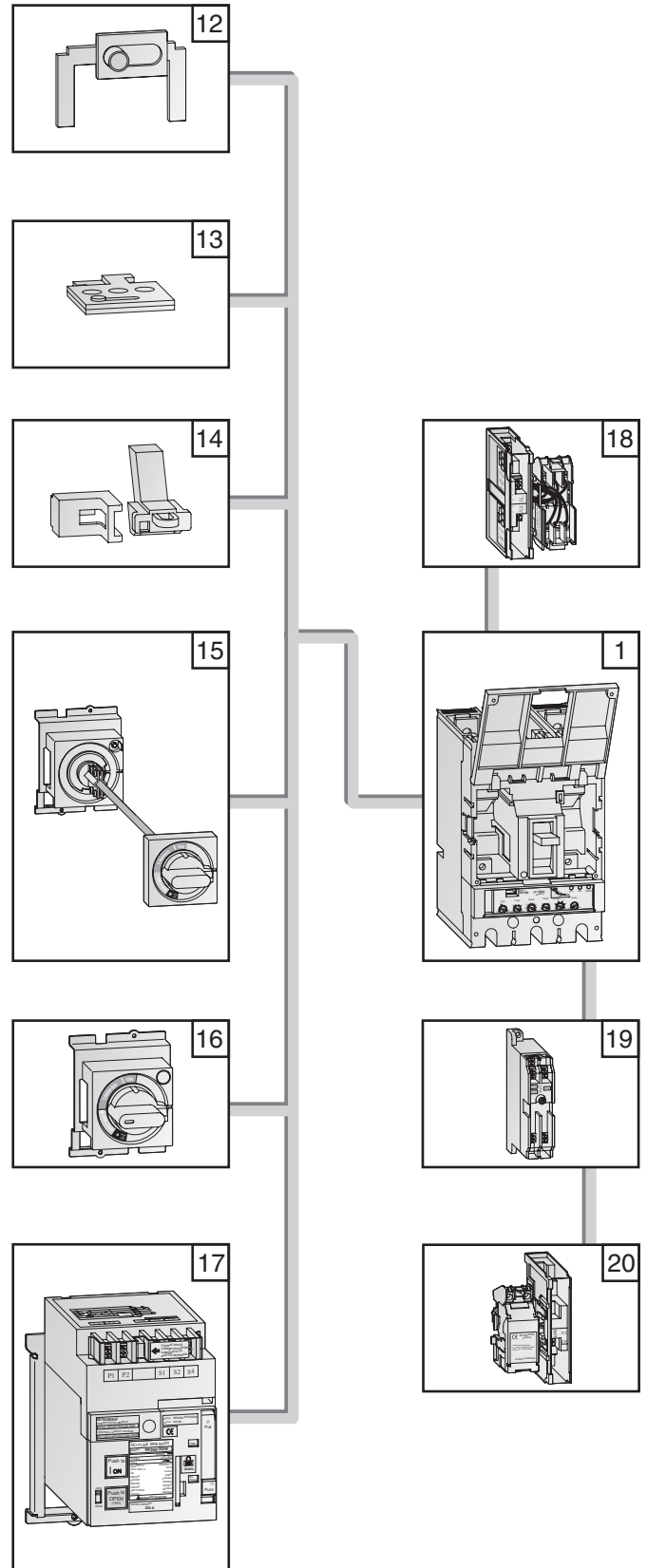

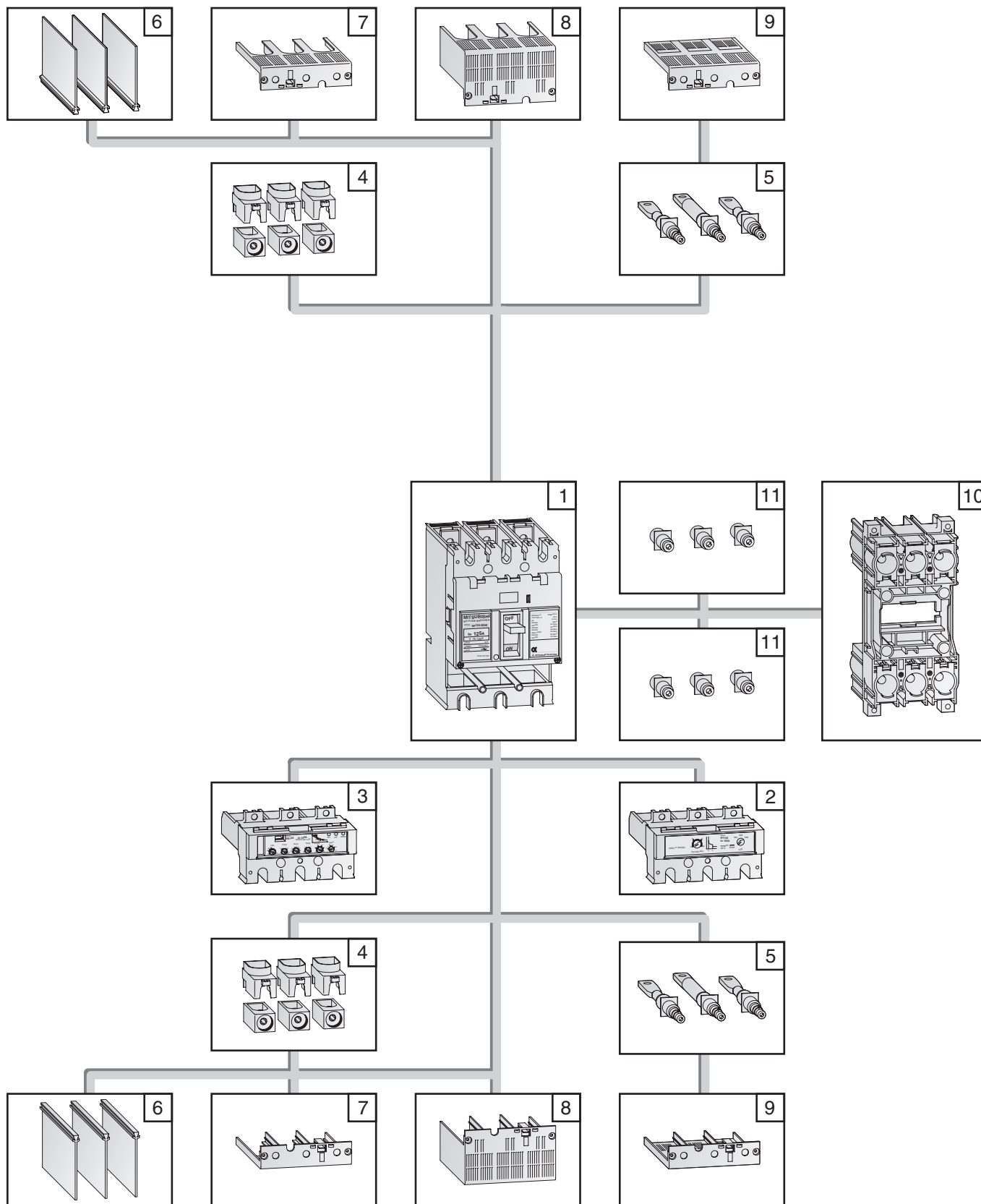

Model Overview and Specifications

1 INTRODUCTION AND CONFIGURATION

Type / Series		WSS series						
		NF32-SW	NF63-SW	NF125-SGW RT	NF125-SGW RE	NF160-SGW RT	NF160-SGW RE	
S series	Rated current $I_{n \max}$ [A]	32	63	125*	125*	160*	160*	
	Rated insulation voltage U_i [V]	AC 600	600	690	690	690	690	
	Number of poles	3	3 / 4	3 / 4	3 / 4	3 / 4	3 / 4	
	Rated breaking capacity [kA] <small>IEC 947-2 EN 60 947-2 VDE 0660</small>	AC ^① (50/60 Hz)	690 V	—	—	8 / 8	8 / 8	8 / 8
			500 V	2.5 / 1	7.5 / 4	30 / 30	30 / 30	30 / 30
			440 V	2.5 / 1	7.5 / 4	36 / 36	36 / 36	36 / 36
			400 V	5 / 2	7.5 / 4	36 / 36	36 / 36	36 / 36
(I_{cu} / I_{cs})	230 V	7.5 / 4	15 / 8	85 / 85	85 / 85	85 / 85		
Dimensions WxHxD	[mm]	75x130x68	75/100x130x68	105/140x165x86	105/140x165x86	105/140x165x86	105/140x165x86	
Type		NF63-HW NF125-HGW RT NF125-HGW RE NF160-HGW RT NF160-HGW RE						
H series	Rated current $I_{n \max}$ [A]		63	125*	125*	160*	160*	
	Rated insulation voltage U_i [V]		690	690	690	690	690	
	Number of poles		3 / 4	3 / 4	3 / 4	3 / 4	3 / 4	
	Rated breaking capacity [kA] <small>IEC 947-2 EN 60 947-2 VDE 0660</small>	AC ^① (50/60 Hz)	690 V	2.5 / 1	20 / 20	20 / 20	20 / 20	20 / 20
			500 V	7.5 / 4	50 / 50	50 / 50	50 / 50	50 / 50
			440 V	10 / 5	65 / 65	65 / 65	65 / 65	65 / 65
			400 V	10 / 5	75 / 75	75 / 75	75 / 75	75 / 75
(I_{cu} / I_{cs})	230 V	25 / 13	100 / 100	100 / 100	100 / 100	100 / 100		
Dimensions WxHxD	[mm]		75/100x130x68	105/140x165x86	105/140x165x86	105/140x165x86	105/140x165x86	
Type		NF125-RGW RT						
R series	Rated current $I_{n \max}$ [A]			100				
	Rated insulation voltage U_i [V]			690				
	Number of poles			3				
	Rated breaking capacity [kA] <small>IEC 947-2 EN 60 947-2 VDE 0660</small>	AC ^① (50/60 Hz)	690 V		25 / 25			
			500 V		125 / 125			
			440 V		125 / 125			
			400 V		125 / 125			
(I_{cu} / I_{cs})	230 V		125 / 125					
Dimensions WxHxD	[mm]			105x240x86				
Type		NF125-UGW RT						
U series	Rated current $I_{n \max}$ [A]			100				
	Rated insulation voltage U_i [V]			690				
	Number of poles			3 / 4				
	Rated breaking capacity [kA] <small>IEC 947-2 EN 60 947-2 VDE 0660</small>	AC ^① (50/60 Hz)	690 V		30 / 30			
			500 V		200 / 200			
			440 V		200 / 200			
			400 V		200 / 200			
(I_{cu} / I_{cs})	230 V		200 / 200					
Dimensions WxHxD	[mm]			105/140x240x86				
Type		DSN32-SW DSN63-SW		DSN125-SGW		DSN160-SGW		
Disconnectors	Rated current $I_{n \max}$ [A]		32	63	125		160	
	Rated insulation voltage U_i [V]	AC/DC	600	600	690		690	
	Rated voltage U_c [V]	AC (50/60 Hz) / DC	500 / 250	500 / 250	690 / 300		690 / 300	
	Number of poles		3	3 / 4	3 / 4		3 / 4	
	Max. switching current [A] (breaking)	AC/DC	256 / 128	504 / 252	1000 / 500		1280 / 640	
	Dimensions WxHxD		75x130x68	75/120x130x68	105/140x165x86		105/140x165x86	

① DC on request ② In case of solderless terminal, interrupting capacity reduces. * adjustable

WSS series								
NF250-SGW RT	NF250-SGW RE	NF400-SEW	NF630-SEW	NF800-SEW	NF1000-SEW	NF1250-SEW	NF1600-SEW	
250*	250*	400*	630*	800*	1000*	1250*	1600*	
690	690	690	690	690	690	690	690	
3 / 4	3 / 4	3 / 4	3 / 4	3 / 4	3 / 4	3 / 4	3 / 4	
8 / 8	8 / 8	10 / 10 ^②	10 / 10	10 / 10	25 / 13	25 / 13	25 / 13	
30 / 30	30 / 30	30 / 30 ^②	30 / 30	30 / 30	65 / 33	65 / 33	65 / 33	
36 / 36	36 / 36	42 / 42 ^②	42 / 42	42 / 42	85 / 43	85 / 43	85 / 43	
36 / 36	36 / 36	50 / 50^②	50 / 50	50 / 50	85 / 43	85 / 43	85 / 43	
85 / 85	85 / 85	85 / 85 ^②	85 / 85	85 / 85	125 / 63	125 / 63	125 / 63	
105/140x165x86	105/140x165x86	140/185x257x103	210/280x275x103	210/280x275x103	210/280x406x140	210/280x406x140	210/280x406x140	
NF250-HGW RT	NF250-HGW RE	NF400-HEW	NF630-HEW	NF800-HEW				
250*	250*	400*	630*	800*				
690	690	690	690	690				
3 / 4	3 / 4	3 / 4	3 / 4	3 / 4				
20 / 20	20 / 20	10 / 10	15 / 15	15 / 15				
50 / 50	50 / 50	50 / 50	50 / 50	50 / 50				
65 / 65	65 / 65	65 / 65	65 / 65	65 / 65				
75 / 75	75 / 75	70 / 70	70 / 70	70 / 70				
100 / 100	100 / 100	100 / 100	100 / 100	100 / 100				
105/140x165x86	105/140x165x86	140/185x257x103	210/280x275x103	210/280x275x103				
NF250-RGW RT			NF400-REW	NF630-REW	NF800-REW			
225			400*	630*	800*			
690			690	690	690			
3			3	3	3			
25 / 25			15 / 10	20 / 15	20 / 15			
125 / 125			70 / 35	70 / 35	70 / 35			
125 / 125			125 / 63	125 / 63	125 / 63			
125 / 125			125 / 63	125 / 63	125 / 63			
125 / 125			150 / 75	150 / 75	150 / 75			
105x240x86			140x257x103	210x275x103	210x275x103			
NF250-UGW RT			NF400-U EW			NF800-U EW		
225			400*			800*		
690			690			690		
3 / 4			3 / 4			3 / 4		
30 / 30			35 / 35			35 / 35		
200 / 200			170 / 170			170 / 170		
200 / 200			200 / 200			200 / 200		
200 / 200			200 / 200			200 / 200		
200 / 200			200 / 200			200 / 200		
105/140x240x86			140/280x297/322x200			210/280x322x200		
DSN250-SGW			DSN400-SW	DSN630-SW	DSN800-SW	DSN1000-SW	DSN1250-SW	DSN1600-SW
250			400	630	800	1000	1250	1600
690			690	690	690	660	660	660
690 / 300			690 / 250	690 / 250	690 / 250	660 / 250	660 / 250	660 / 250
3 / 4			3 / 4	3 / 4	3 / 4	3 / 4	3 / 4	3 / 4
2000 / 1000			3200 / 1600	5040 / 2520	6400 / 3200	8000 / 14000	10000 / 5000	12800 / 6400
105/140x165x86			140/185x257x103	210/280x275x103	210/280x275x103	210/280x406x140	210/280x406x140	210/280x406x140

* adjustable

Specifications of Moulded-Case Circuit Breakers 3–125 A

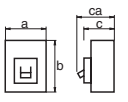
Type		(Reference for Order information on p. 22)	NF32-SW (1)	NF63-SW (2)	NF63-HW (3)	NF125-SGW RT (4)	NF125-SGW RE (5)		
Frame (A)			32	63	63	125	125		
Rated data	Rated current I_n [A] at ambient temperature	40 °C	3, 4, 6, 10, 16, 20, 25, 32 Fixed	3, 4, 6, 10, 16, 20, 25, 32, 40, 50, 63 Fixed	10, 16, 20, 25, 32, 40, 50, 63 Fixed	16–25, 25–40, 40–63, 63–100, 80–125 Adjustable	16–32, 32–63, 63–100, 75–125 Adjustable		
	Number of poles		3	3 / 4	3 / 4	3 / 4	3 / 4		
	Rated insulation voltage U_i [V]	AC	600	600	690	690	690		
	Rated breaking capacity [kA]	IEC/EN 60947-2	AC (50/60 Hz)	690 V	—	—	2.5 / 1	8 / 8	8 / 8
				500 V	2.5 / 1	7.5 / 4	7.5 / 4	30 / 30	30 / 30
				440 V	2.5 / 1	7.5 / 4	10 / 5	36 / 36	36 / 36
				400 V	5 / 2	7.5 / 4	10 / 5	36 / 36	36 / 36
				230 V	7.5 / 4	15 / 8	25 / 13	85 / 85	85 / 85
	(I_{cu} / I_{cs})		DC	300 V	—	—	20 / 20 ^④	—	
Utilization category			A	A	A	A	A		
Rated impulse withstand voltage U_{imp} [kV]			6	6	6	8	8		
Pollution degree			2	2	2	3	3		
Reverse connection			●	●	●	●	●		
Suitable for isolation 			●	●	●	●	●		
Dimensions [mm]		a	75	75 / 100	75 / 100	105 / 140	105 / 140		
		b	130	130	130	165	165		
		c	68	68	68	86	86		
		ca	90	90	90	110	110		
		Weight [kg]		0.55	0.60 / 0.70	0.60 / 0.70	2.0 / 2.6	2.0 / 2.6	
Mechanical data	Cassette-type accessories	Alarm switch (AL)	●	●	●	●	●		
		Auxiliary switch (AX)	●	●	●	●	●		
		Shunt trip (SHT)	●	●	●	●	●		
		Undervoltage trip	Non-synchronous closing (UVT-N)	●	●	●	●	●	
			Synchronous closing (UVT-S)	—	—	—	—	—	
	Accessories connection	with terminal block (SLT)	●	●	●	●	●		
		with internal terminal type	●	●	●	●	●		
	Installation and connection	Front	Screw terminal (standard)	●	●	●	●	●	
			Solderless terminal	—	—	—	●	●	
			Busbar terminal	—	—	—	—	—	
Rear		(B)	●	●	●	●	●		
Plug-in		Rear (PM)	●	●	●	—	—		
	Rear front IP 20 with auto trip (PM-IP)	—	—	—	●	●			
Built-in accessories	Pre-alarm-contact output ^① (PAL)	—	—	—	—	●			
	Overcurrent trip alarm ^① (OAL)	—	—	—	—	●			
External accessories	External operating handle	Door mounting (V)	●	●	●	●	●		
		Mounted on breaker (R)	—	—	—	●	●		
	Electrical operation device (MDS)	—	—	—	●	●			
	Handle lock device	Handle lock for use with padlock (HL)	●	●	●	●	●		
		(HL-S)	●	●	●	●	●		
		Lock cover (LC)	●	●	●	●	●		
	Terminal cover	Large (TC-L)	●	●	●	●	●		
		Small (TC-S)	●	●	●	●	●		
		For rear connection (BTC)	●	●	●	●	●		
		For plug-in (PTC)	●	●	●	●	●		
Mechanical interlock (MI)	●	●	●	●	●				
Insulating barrier Between phase (Standard) (BA-F)	●	●	●	●	●				
Adapter for IEC 35 mm rail	●	●	●	—	—				
Others	Marine approval ^③ for 3 pole breakers		LR, GL, BV, DNV, AB	LR, GL, BV, DNV, AB	LR, GL, BV, DNV, AB	LR, GL, BV, DNV, AB	LR, GL, BV, DNV, AB		
	Automatic tripping device		Hydraulic-magnetic	Hydraulic-magnetic	Hydraulic-magnetic	Thermal-magnetic	Electronic		
	Trip button		Equipped	Equipped	Equipped	Equipped	Equipped		

① Both PAL and OAL is not available. Only one specified. ② Others on request. ③ On request. ④ Use of 3- or 4-pole breaker for DC, see wiring diagram on the next page. Missing specifications accord. to IEC/EN 60947-2 on request.

NF125-HGW RT (6)	NF125-HGW RE (7)	NF125-RGW RT (8)	NF125-UGW RT (9)
125	125	125	125
16-25, 25-40, 40-63, 63-100, 80-125 Adjustable	16-32, 32-63, 63-100, 75-125 Adjustable	16-25, 25-40, 40-63, 63-100 Adjustable	16-25, 25-40, 40-63, 63-100 Adjustable
3 / 4	3 / 4	3	3 / 4
690	690	690	690
20 / 20	20 / 20	25 / 25	30 / 30
50 / 50	50 / 50	125 / 125	200 / 200
65 / 65	65 / 65	125 / 125	200 / 200
75 / 75	75 / 75	125 / 125	200 / 200
100 / 100	100 / 100	125 / 125	200 / 200
40 / 40 ^②	—	—	—
A	A	A	A
8	8	8	8
3	3	3	3
●	●	●	●
●	●	●	●
105 / 140	105 / 140	105	105 / 140
165	165	240	240
86	86	86	86
110	110	110	110
2.0 / 2.6	2.0 / 2.6	3.1	3.1 / 3.9
●	●	●	●
●	●	●	●
●	●	●	●
●	●	●	●
—	—	—	—
●	●	●	●
●	●	●	●
●	●	●	●
●	●	●	●
—	—	—	—
●	●	●	●
—	—	—	— / ●
●	●	●	● / —
—	●	—	—
—	●	—	—
●	●	●	●
●	●	●	●
●	●	●	●
●	●	●	●
●	●	●	●
●	●	●	●
●	●	●	●
●	●	●	●
●	●	●	●
●	●	●	●
●	●	●	●
●	●	●	●
—	—	—	—
LR, GL, BV, DNV, AB	LR, GL, BV, DNV, AB	LR, GL, BV, DNV, AB	LR, GL, BV, DNV, AB
Thermal-magnetic	Electronic	Thermal-magnetic	Thermal-magnetic
Equipped	Equipped	Equipped	Equipped

Use of 3- and 4-pole breakers for DC

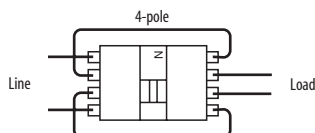
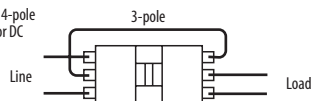

Specifications of Moulded-Case Circuit Breakers 160–250 A

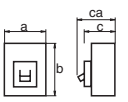
Type	(Reference for Order information on p.23)	NF160-SGW RT (10)	NF160-SGW RE (11)	NF160-HGW RT (12)	NF160-HGW RE (13)		
Frame (A)		160	160	160	160		
Rated data	Rated current I_n [A] at ambient temperature	40 °C 125–160 Adjustable	80–160 Adjustable	125–160 Adjustable	80–160 Adjustable		
	Number of poles	3 / 4	3 / 4	3 / 4	3 / 4		
	Rated insulation voltage U_i [V]	AC 690 V	690	690	690		
	Rated breaking capacity [kA] (IEC/EN 60947-2)	AC (50/60 Hz)	690 V	8 / 8	8 / 8	20 / 20	
			500 V	30 / 30	30 / 30	50 / 50	
			440 V	36 / 36	36 / 36	65 / 65	
			400 V	36 / 36	36 / 36	75 / 75	
			230 V	85 / 85	85 / 85	100 / 100	
		DC	300 V	20 / 20 ^④	—	40 / 40 ^④	—
	Utilization category	A	A	A	A		
Rated impulse withstand voltage U_{imp} [kV]	8	8	8	8			
Pollution degree	3	3	3	3			
Reverse connection		●	●	●	●		
Suitable for isolation 		●	●	●	●		
Mechanical data	Dimensions [mm]		a	105 / 140	105 / 140	105 / 140	105 / 140
			b	165	165	165	165
			c	86	86	86	86
			ca	110	110	110	110
			Weight [kg]	2.0 / 2.6	2.0 / 2.6	2.0 / 2.6	2.0 / 2.6
	Cassette-type accessories	Alarm switch (AL)	●	●	●	●	
		Auxiliary switch (AX)	●	●	●	●	
		Shunt trip (SHT)	●	●	●	●	
		Undervoltage trip	Non-synchronous dosing (UVT-N)	—	—	—	—
		Synchronous closing (UVT-S)	●	●	●	●	
Accessories connection	with terminal block (SLT)	●	●	●	●		
	with internal terminal type	●	●	●	●		
Installation and connection	Front	Screw terminal (standard)	●	●	●	●	
		Solderless terminal	●	●	●	●	
		Busbar terminal	—	—	—	—	
	Rear (B)	●	●	●	●		
	Plug-in	Rear (PM)	—	—	—	—	
	Rear front IP 20 with auto trip (PM-IP)	●	●	●	●		
Built-in accessories	Pre-alarm-contact output ^① (PAL)	—	●	—	●		
	Overcurrent trip alarm ^① (OAL)	—	●	—	●		
External accessories	External operating handle	Door mounting (V)	●	●	●	●	
		Mounted on breaker (R)	●	●	●	●	
	Electrical operation device (MDS)	●	●	●	●		
	Handle lock device	Handle lock for use with padlock (HL)	●	●	●	●	
		(HL-S)	●	●	●	●	
		Lock cover (LC)	●	●	●	●	
	Terminal cover	Large (TC-L)	●	●	●	●	
		Small (TC-S)	●	●	●	●	
		For rear connection (BTC)	●	●	●	●	
		For plug-in (PTC)	●	●	●	●	
	Mechanical interlock (MI)	●	●	●	●		
	Insulating barrier Between phase (Standard) (BA-F)	●	●	●	●		
	Adapter for IEC 35 mm rail	—	—	—	—		
Others	Marine approval ^② for 3 pole breakers	—	—	—	—		
	Automatic tripping device	Thermal-magnetic	Electronic	Thermal-magnetic	Electronic		
	Trip button	Equipped	Equipped	Equipped	Equipped		

① Both PAL and OAL is not available. Only one specified. ② Others on request. ③ On request. ④ Use of 3- or 4-pole breaker for DC, see wiring diagram on the next page. Missing specifications accord. to IEC/EN 60947-2 on request.

NF250-SGW RT (14)	NF250-SGW RE (15)	NF250-HGW RT (16)	NF250-HGW RE (17)	NF250-RGW RT (18)	NF250-UGW RT (19)
250	250	250	250	250	250
125-160, 160-250 Adjustable	125-250 Adjustable	125-160, 160-250 Adjustable	125-250 Adjustable	125-160, 160-225 Adjustable	125-160, 160-225 Adjustable
3/4	3/4	3/4	3/4	3	3/4
690	690	690	690	690	690
8/8	8/8	20/20	20/20	25/25	30/30
30/30	30/30	50/50	50/50	125/125	200/200
36/36	36/36	65/65	65/65	125/125	200/200
36/36	36/36	75/75	75/75	125/125	200/200
85/85	85/85	100/100	100/100	125/125	200/200
20/20 ⁽⁴⁾	—	40/40 ⁽⁴⁾	—	—	—
A	A	A	A	A	A
8	8	8	8	8	8
3	3	3	3	3	3
●	●	●	●	●	●
●	●	●	●	●	●
105/140	105/140	105/140	105/140	105	105/140
165	165	165	165	240	240
86	86	86	86	86	86
110	110	110	110	110	110
2.0/2.6	2.0/2.6	2.0/2.6	2.0/2.6	3.1	3.1/3.9
●	●	●	●	●	●
●	●	●	●	●	●
●	●	●	●	●	●
●	●	●	●	●	●
●	●	●	●	●	●
●	●	●	●	●	●
—	—	—	—	—	—
●	●	●	●	●	●
—	—	—	—	—	—/●
●	●	●	●	●	—
—	●	—	●	—	—
—	●	—	●	—	—
●	●	●	●	●	●
●	●	●	●	●	●
●	●	●	●	●	●
●	●	●	●	●	●
●	●	●	●	●	●
●	●	●	●	●	●
●	●	●	●	●	●
●	●	●	●	●	●
●	●	●	●	●	●
●	●	●	●	●	●/—
●	●	●	●	●	●
●	●	●	●	●	●
—	—	—	—	—	—
LR, GL, BV, DNV, AB	LR, GL, BV, DNV, AB	LR, GL, BV, DNV, AB	LR, GL, BV, DNV, AB	LR, GL, BV, DNV, AB	LR, GL, BV, DNV, AB
Thermal-magnetic	Electronic	Thermal-magnetic	Electronic	Thermal-magnetic	Thermal-magnetic
Equipped	Equipped	Equipped	Equipped	Equipped	Equipped

Use of 3- and 4-pole breakers for DC

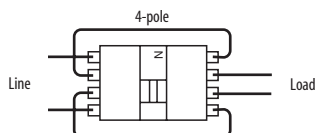
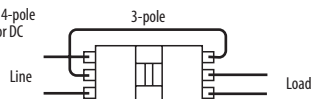

Specifications of Moulded-Case Circuit Breakers 400–630 A

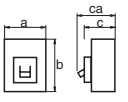
Type		(Reference for Order information on p. 23)	NF400-SEW (20)	NF400-HEW (21)	NF400-REW (22)	
Frame (A)			400	400	400	
Rated data	Rated current I_n [A] at ambient temperature	40 °C	200–400 Adjustable	200–400 Adjustable	200–400 Adjustable	
	Number of poles		3 / 4	3 / 4	3	
	Rated insulation voltage U_i [V]	AC	690	690	690	
	Rated breaking capacity [kA] (I_{cu} / I_{cs})	IEC/EN 60947-2 AC ^① (50/60 Hz)	690 V	10 / 10 (5 / 5) ^②	10 / 10	15 / 10
			500 V	30 / 30 (25 / 25) ^②	50 / 50	70 / 35
			440 V	42 / 42 (36 / 36) ^②	65 / 65	125 / 63
			400 V	50 / 50 (36 / 36)^②	70 / 70	125 / 63
			230 V	85 / 85 (65 / 65) ^②	100 / 100	150 / 75
	Utilization category		B	B	B	
	Rated short-time withstand current I_{cw} [kA/s]		5 / 0.25	5 / 0.25	5 / 0.25	
	Rated impulse withstand voltage U_{imp} [kV]		8	8	8	
	Pollution degree		3	3	3	
	Reverse connection		●	●	●	
Suitable for isolation 		●	●	●		
Dimensions [mm]		a	140 / 185	140 / 185	140	
		b	257	257	257	
		c	103	103	103	
		ca	155	155	155	
		Weight [kg]		6.0 / 7.8	6.0 / 7.8	6.0
Mechanical data	Cassette-type accessories	Alarm switch (AL)	●	●	●	
		Auxiliary switch (AX)	●	●	●	
		Shunt trip (SHT)	●	●	●	
		Undervoltage trip	Non-synchronous closing (UVT-N)	●	●	●
			Synchronous closing (UVT-S)	●	●	●
	Accessories connection	with terminal block (SLT)	●	●	●	
		with internal terminal type ^③	●	●	●	
	Installation and connection	Front	Busbar terminal (standard)	●	●	●
		Rear	(B)	●	●	●
		Plug-in	Rear (PM)	●	●	●
Built-in accessories	Pre-alarm-contact output (PAL)	●	●	●		
	Trip indicator (TI)	●	●	●		
External accessories	External operating handle	Door mounting (V)	●	●	●	
		Mounted on breaker (R)	●	●	●	
	Electrical operation device	Spring-charge type (MDS)	●	●	●	
	Handle lock device	Handle lock for use with padlock (HL)	●	●	●	
		(HL-S)	●	●	●	
	Terminal cover	Large (TC-L)	●	●	●	
		For rear connection (BTC)	●	●	●	
	Mechanical interlock (MI)	●	●	●		
	Insulating barrier	Between phase (Standard) (BA-F)	●	●	●	
	Others	Marine approval ^④ for 3 pole breakers	LR, GL, BV, DN, AB	LR, GL, BV, AB	LR, GL, BV, AB	
Automatic tripping device		Electronic	Electronic	Electronic		
Trip button		Equipped	Equipped	Equipped		

① DC type on request. ② In case of solderless terminal, interrupting capacity reduces. ③ On request. ④ Others on request. Missing specifications accord. to IEC/EN 60947-2 on request.

NF400-U EW (23) 400	NF630-SEW (24) 630	NF630-HEW (25) 630	NF630-REW (26) 630
200-400 Adjustable	300-630 Adjustable	300-630 Adjustable	300-630 Adjustable
3 / 4	3 / 4	3 / 4	3
690	690	690	690
35 / 35	10 / 10	35 / 18	20 / 15
170 / 170	30 / 30	50 / 50	70 / 35
200 / 200	42 / 42	65 / 65	125 / 63
200 / 200	50 / 50	70 / 70	125 / 63
200 / 200	85 / 85	100 / 100	150 / 75
B	B	B	B
5 / 0.25	7.6 / 0.25	7.6 / 0.25	7.6 / 0.25
8	8	8	8
3	3	3	3
●	●	●	●
●	●	●	●
140 / 280	140 / 185	140 / 185	140
297 / 322	257	257	257
200	103	103	103
252	155	155	155
16.7 / 26.1	6.5 / 8.3	6.5 / 8.3	6.5
●	●	●	●
●	●	●	●
●	●	●	●
●	●	●	●
●	●	●	●
●	●	●	●
●	●	●	●
●	●	●	●
●	●	●	●
● / —	●	●	●
●	●	●	●
●	●	●	●
—	●	●	●
—	●	●	●
—	●	●	●
●	●	●	●
●	●	●	●
●	●	●	●
●	●	●	●
●	●	●	●
●	●	●	●
LR, GL, BV, AB	LR, GL, BV, AB	LR, GL, BV, AB	LR, GL, BV, AB
Electronic	Electronic	Electronic	Electronic
Equipped	Equipped	Equipped	Equipped

Specifications of Moulded-Case Circuit Breakers 800–1600 A

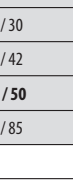
Type	(Reference for Order information on p. 23)	NF800-SEW (27)	NF800-HEW (28)	NF800-REW (29)		
Frame (A)		800	800	800		
Rated data	Rated current I_n [A] at ambient temperature	40 °C	400–800 Adjustable	400–800 Adjustable	400–800 Adjustable	
	Number of poles		3 / 4	3 / 4	3	
	Rated insulation voltage U_i [V]	AC	690	690	690	
	Rated breaking capacity [kA] (IEC/EN 60947-2 AC ^① (50/60 Hz))	690 V	10 / 10	15 / 15	—	
		500 V	30 / 30	50 / 50	70 / 35	
		440 V	42 / 42	65 / 65	125 / 63	
		400 V	50 / 50	70 / 70	125 / 63	
		230 V	85 / 85	100 / 100	150 / 75	
	(I_{cu} / I_{cs})					
	Utilization category		B	B	B	
	Rated short-time withstand current I_{cw} [kA/s]		9.6 / 0.25	9.6 / 0.25	9.6 / 0.25	
	Rated impulse withstand voltage U_{imp} [kV]		8	8	8	
	Pollution degree		3	3	3	
Reverse connection		●	●	●		
Suitable for isolation 		●	●	●		
Dimensions [mm]		a	210 / 280	210 / 280	210	
		b	275	275	275	
		c	103	103	103	
		ca	155	155	155	
		Weight [kg]		10.9 / 14.2	10.9 / 14.2	10.9
Mechanical data	Cassette-type accessories	Alarm switch (AL)	●	●	●	
		Auxiliary switch (AX)	●	●	●	
		Shunt trip (SHT)	●	●	●	
		Undervoltage trip	Non-synchronous closing (UVT-N)	●	●	●
			Synchronous closing (UVT-S)	●	●	●
	Accessories connection	with terminal block (SLT)	●	●	●	
		with internal terminal type ^②	●	●	●	
	Installation and connection	Front	Busbar terminal (Standard)	●	●	●
		Rear	(B)	●	●	●
		Plug-in	Rear (PM)	●	●	●
Built-in accessories	Pre-alarm-contact output (PAL)	●	●	●		
	Trip indicator (TI)	●	●	●		
External accessories	External operating handle	Door mounting (V)	●	●	●	
		Mounted on breaker (R)	●	●	●	
	Electrical operation device	Spring-charge type (MDS)	●	●	●	
	Handle lock device	Handle lock for use with padlock (HL)	●	●	●	
		(HL-S)	●	●	●	
	Terminal cover	Large (TC-L)	●	●	●	
		For rear connection (BTC)	●	●	●	
	Mechanical interlock (MI)	●	●	●		
	Insulating barrier	Between phase (Standard) (BA-F)	●	●	●	
	Others	Marine approval ^③ for 3 pole breakers	LR, GL, BV, DN, AB	LR, GL, BV, AB	LR, GL, BV, AB	
Automatic tripping device		Electronic	Electronic	Electronic		
Trip button		Equipped	Equipped	Equipped		

① DC type on request. ② On request. ③ Others on request. ④ Assembly by factory.
Missing Specifications accord. to IEC/EN 60947-2 on request.

NF800-UEW ⁽³⁰⁾ 800	NF1000-SEW ⁽³¹⁾ 1000	NF1250-SEW ⁽³²⁾ 1250	NF1600-SEW ⁽³³⁾ 1600
400–800 Adjustable	500–1000 Adjustable	600–1250 Adjustable	800–1600 Adjustable
3 / 4	3 / 4	3 / 4	3 / 4
690	690	690	690
35 / 35	25 / 13	25 / 13	25 / 13
170 / 170	65 / 33	65 / 33	65 / 33
200 / 200	85 / 43	85 / 43	85 / 43
200 / 200	85 / 43	85 / 43	85 / 43
200 / 200	125 / 63	125 / 63	125 / 63
B	B	B	B
9.6 / 0.25	20 / 0.3	20 / 0.3	20 / 0.3
8	8	8	8
3	3	3	3
●	●	●	●
●	●	●	●
210 / 280	210 / 280	210 / 280	210 / 280
322	406	406	406
200	140	140	140
252	190	190	190
27.6 / 33.7	23.5 / 30.7	23.5 / 30.7	34.5 / 41.2
●	●	●	●
●	●	●	●
●	●	●	●
●	●	●	●
●	●	●	●
●	●	●	●
●	●	●	●
●	●	●	●
●	●	●	●
●	●	●	●
●	●	●	●
●	●	●	●
—	—	—	—
●	●	●	●
●	●	●	●
—	●	●	●
—	●	●	●
●	●	●	●
●	●	●	●
●	—	—	—
●	●	●	—
●	—	—	—
●	●	●	●
●	●	●	●
—	LR, GL, AB	LR, GL, AB	—
Electronic	Electronic	Electronic	Electronic
Equipped	Equipped	Equipped	Equipped

Specifications of Disconnectors DSN, IEC 60947-3, EN 60947-3

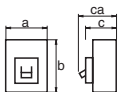
Type	(Reference for Order information on p. 23)	DSN32-SW (34)	DSN63-SW (35)	DSN125-SGW (36)	DSN160-SGW (37)	DSN250-SGW (38)		
Rated data	Rated current I_n [A]	40 °C	32	63	125	160	250	
	Number of poles		3	3 / 4	3 / 4	3 / 4	3 / 4	
	Rated insulation voltage U_i [V]	AC	600	600	600	690	690	
		DC	250	250	250	250	250	
	Rated voltage U_c [V]	AC	500	600	690	690	690	
		DC	250	250	300	300	300	
	Rated impulse withstand voltage U_{imp} [kV]	kV	6	6	8	8	8	
	Pollution degree		2	2	2	2	2	
	Utilization category		AC-23A, DC-23A	AC-23A, DC-23A	AC-23A, DC-23A	AC-23A, DC-23A	AC-23A, DC-23A	
	Making and breaking current	Making current AC / DC cycles	A	320 / 128	630 / 252	1250 / 500	1600 / 640	2500 / 1000
		Breaking current AC / DC cycles	A	256 / 128	504 / 252	1000 / 500	1280 / 640	2000 / 1000
	Operational performance	Without current		10000	10000	50000	40000	25000
		With current (440 V / 690 V)		6000 / —	6000 / —	30000 / 1000	20000 / 1000	10000 / 1000
	Short-time withstand current I_{cw}	1 s	A	1000	1000	2000	3000	4000
Short-circuit making capacity I_{cm}	1 s	A	1500	1500	3000	4000	6000	
Max. switching current ①	AC / DC	A	192 / 80	378 / 157.5	750 / 312.5	960 / 400	1500 / 625	
	cycles		12	12	12	12	12	
Suitable for isolation 			●	●	●	●	●	
Dimensions [mm]		a	75	75 / 100	75 / 100	90 / 120	105 / 140	
		b	130	130	165	165	165	
		c	68	68	68	68	68	
		ca	90	90	110	110	110	
	Weight [kg]		0.55	0.60	2.0 / 2.6	2.0 / 2.6	2.0 / 2.6	
Mechanical data	Cassette-type accessories	Alarm switch (AL)	●	●	●	●	●	
		Auxiliary switch (AX)	●	●	●	●	●	
		Shunt trip (SHT)	●	●	●	●	●	
		Undervoltage trip (UVT)	●	●	●	●	●	
Accessories connection	with terminal block (SLT)	●	●	●	●	●		
	with internal terminal type ②	●	●	●	●	●		
Installation and connection	Front	Screw terminal	● ③	● ③	● ③	● ③	● ③	
		Solderless terminal	—	—	●	●	●	
	Busbar terminal	●	●	●	●	●		
	Rear (B)	●	●	●	●	●		
	Plug-in	Rear (PM)	●	●	●	●	●	
	Rear front IP 20 with auto trip (PM-IP)	—	—	●	●	●		
External accessories	External operating handle	Door mounting (V)	●	●	●	●	●	
		Mounted on breaker (R)	—	—	●	●	●	
	Electrical operation device (MDS)	—	—	●	●	●		
	Handle lock device	Handle lock for use with padlock (HL)	●	●	●	●	●	
		Lock cover (HL-S)	●	●	●	●	●	
		Lock cover (LC)	●	●	●	●	●	
	Terminal cover	Large (TC-L)	●	●	●	●	●	
		Small (TC-S)	●	●	● / —	● / —	●	
		For rear connection (BTC)	●	●	● / —	● / —	●	
	Mechanical interlock (MI)	●	●	●	●	●		
	Insulating barrier	Between phase (Standard) (BA-F)	●	●	●	●	●	
Adapter for IEC 35 mm rail		●	●	—	—	—		
Corresponding type of circuit breaker		NF32-SW	NF63-SW	NF125-SGW	NF160-SGW	NF250-SGW		

① This performance is accordance with IEC60947-2 clause 7.2.4.1. ② On request. ③ Standard. ④ Assembly by factory. ⑤ TC-N. Missing specifications accord. to IEC/EN 60947-2 on request.

DSN400-SW (39)	DSN630-SW (40)	DSN800-SW (41)	DSN1000-SW (42)	DSN1250-SW (43)	DSN1600-SW (44)
400	630	800	1000	1250	1600
3/4	3/4	3/4	3/4	3/4	3/4
690	690	690	690	690	690
250	250	250	250	250	250
690	690	690	690	690	690
250	250	250	250	250	250
8	8	8	8	8	8
3	3	3	3	3	3
AC-23A, DC-23A	AC-23A, DC-23A	AC-23A, DC-23A	AC-23A, DC-23A	AC-23A, DC-23A	AC-23A, DC-23A
4000 / 1600	6300 / 2520	8000 / 3200	10000 / 4000	12500 / 5000	16000 / 6400
3/5	3/5	3/5	3/5	3/5	3/5
3200 / 1600	5040 / 2520	6400 / 3200	8000 / 4000	10000 / 5000	12800 / 6400
3/5	3/5	3/5	3/5	3/5	3/5
4000	4000	2500	2500	2500	2500
1000	1000	500	500	500	500
6000	8000	10000	12000	12000	16000
10200	13600	17000	24000	24000	32000
2400 / 1000	3780 / 1575	4800 / 2000	6000 / 2500	7500 / 3125	9600 / 4000
12	12	12	12	12	12
●	●	●	—	—	—
140 / 185	210 / 280	210 / 280	210 / 280	210 / 280	210 / 280
257	275	275	406	406	406
103	103	103	140	140	140
155	155	155	190	190	190
5.7 / 7.5	8.5 / 12.5	10.9 / 14.2	23.0 / 30.2	23.0 / 30.2	34.0 / 40.7
●	●	●	●	●	●
●	●	●	●	●	●
●	●	●	●	●	●
●	●	●	●	●	●
●	●	●	●	●	●
●	●	●	●	●	●
—	—	—	—	—	—
—	—	—	—	—	—
● ^①	● ^①	● ^①	● ^①	● ^①	● ^①
●	●	●	● ^④	● ^④	● ^④
●	●	●	● ^④	● ^④	● ^④
—	—	—	—	—	—
●	●	●	●	●	●
●	●	●	●	●	●
●	●	●	●	●	●
●	●	●	●	●	●
●	●	●	●	●	●
—	—	—	—	—	—
●	●	●	● ^⑤	● ^⑤	—
—	—	—	—	—	—
●	●	●	●	●	●
●	●	●	●	●	●
●	●	●	●	●	●
—	—	—	—	—	—
NF400-SEW	NF630-SEW	NF800-SEW	NF1000-SEW	NF1250-SEW	NF1600-SEW

Order Information for Moulded-Case Circuit Breakers 3–125 A

CIRCUIT BREAKERS 2

Ref. ①	Type	Rated current (In)	Art. no. 3 pole type	Art. no. 4 pole type
S series with hydraulic-magnetic tripping device, fixed, AC				
1	NF32-SW	3 A	204474	—
		4 A	204475	—
		6 A	204477	—
		10 A	204478	—
		16 A	204480	—
		20 A	204481	—
		25 A	204482	—
		32 A	204484	—
2	NF63-SW	3 A	204486	204501
		4 A	204487	204502
		6 A	204489	204504
		10 A	204490	204505
		16 A	204492	204507
		20 A	204493	204508
		25 A	204494	204509
		32 A	204496	204511
		40 A	204497	204512
		50 A	204498	204513
		63 A	204500	204515
H series with hydraulic-magnetic tripping device, fixed, AC				
3	NF63-HW	10 A	204516	204527
		16 A	204518	204529
		20 A	204519	204530
		25 A	204520	204531
		32 A	204522	204533
		40 A	204523	204534
		50 A	204524	204535
		63 A	204526	204537

Ref. ①	Type	Rated current (In)	Art. no. 3 pole type	Art. no. 4 pole type
S series with thermal-magnetic tripping device, AC, DC				
4	NF125-SGW RT	16–25 A	204540	204545
		25–40 A	204541	204546
		40–63 A	204542	204547
		63–100 A	204543	204548
		80–125 A	204544	204549
		—	—	—
S series with electronic tripping device, adjustable, AC				
5	NF125-SGW RE	16–32 A	204550	204554
		32–63 A	204551	204555
		63–100 A	204552	204556
		75–125 A	204553	204557
H series with thermal-magnetic tripping device, adjustable, AC, DC				
6	NF125-HGW RT	16–25 A	204558	204563
		25–40 A	204559	204564
		40–63 A	204560	204565
		63–100 A	204561	204566
		80–125 A	204562	204567
		—	—	—
H series with electronic tripping device, AC				
7	NF125-HGW RE	16–32A	204568	204572
		32–63A	204569	204573
		63–100A	204570	204574
		75–125A	204571	204575
R series with thermal-magnetic tripping device, adjustable, AC				
8	NF125-RGW RT	16–25 A	204576	—
		25–40 A	204577	—
		40–63 A	204578	—
		63–100 A	204579	—
U series with thermal-magnetic tripping device, adjustable, AC				
9	NF125-UGW RT	16–25 A	204580	204584
		25–40 A	204581	204585
		40–63 A	204582	204586
		63–100 A	204583	204587

① Reference to breaker specifications on p. 12ff.

Order Information for Moulded-Case Circuit Breakers 160–250 A

Ref. ^①	Type	Rated current (In)	Art. no. 3 pole type	Art. no. 4 pole type
S series with thermal-magnetic tripping device, AC, DC				
10	NF160-SGW RT	125–160 A	204591	204592
S series with electronic tripping device, AC				
11	NF160-SGW RE	80–160 A	204593	204594
H series with thermal-magnetic tripping device, AC, DC				
12	NF160-HGW RT	125–160 A	204596	204597
H series with electronic tripping device, adjustable, AC				
13	NF160-HGW RE	80–160 A	204598	204599
S series with thermal-magnetic tripping device, adjustable, AC, DC				
14	NF250-SGW RT	125–160 A	212124	212125
		160–250 A	204602	204603
S series with electronic tripping device, adjustable, AC				
15	NF250-SGW RE	125–250 A	204604	204605

Ref. ^①	Type	Rated current (In)	Art. no. 3 pole type	Art. no. 4 pole type
H series with thermal-magnetic tripping device, adjustable, AC, DC				
16	NF250-HGW RT	125–160 A	212126	212127
		160–250 A	204606	204607
H series with electronic tripping device, adjustable, AC				
17	NF250-HGW RE	125–250 A	204608	204609
R series with thermal-magnetic tripping device, adjustable, AC				
18	NF250-RGW RT	160–225 A	204610	—
U series with thermal-magnetic tripping device, adjustable, AC				
19	NF250-UGW RT	125–160 A	204611	204613
		160–225 A	204612	204614

Order Information for Moulded-Case Circuit Breakers 400–800 A

Ref. ^①	Type	Rated current (In)	Art. no. 3 pole type	Art. no. 4 pole type
S series with electronic tripping device, adjustable, AC				
20	NF400-SEW	200–400 A	204780	204781
24	NF630-SEW	300–630 A	204789	204790
37	NF800-SEW	400–800 A	204797	204798
H series with electronic tripping device, adjustable, AC				
21	NF400-HEW	200–400 A	204782	204783
25	NF630-HEW	300–630 A	204791	204792
28	NF800-HEW	400–800 A	204799	204800

Ref. ^①	Type	Rated current (In)	Art. no. 3 pole type	Art. no. 4 pole type
R series with electronic tripping device, adjustable, AC				
22	NF400-REW	200–400 A	204784	—
26	NF630-REW	300–630 A	204793	—
29	NF800-REW	400–800 A	204801	—
U series with electronic tripping device, adjustable, AC				
23	NF400-UEW	200–400 A	204785	204786
30	NF800-UEW	400–800 A	204802	204803

Order Information for Moulded-Case Circuit Breakers 1000–1600 A

Ref. ^①	Type	Rated current (In)	Art. no. 3 pole type	Art. no. 4 pole type
SS/UR series with electronic tripping device, adjustable, AC				
31	NF1000-SEW	500–1000 A	204810	204811
32	NF1250-SEW	600–1250 A	204812	204813
33	NF1600-SEW	800–1600 A	204814	204815

Order Information for Disconnectors DSN series 32–1600 A

Ref. ^①	Type	Rated current (In)	Art. no. 3 pole type	Art. no. 4 pole type
Disconnectors (no tripping device)				
34	DSN32-SW	32 A	204473	—
35	DSN63-SW	63 A	204485	204817
36	DSN125-SGW	125 A	204538	204539
37	DSN160-SGW	160 A	204588	204589
38	DSN250-SGW	250 A	204600	204601
39	DSN400-SW	400 A	204778	204779
40	DSN630-SW	630 A	204787	204788
41	DSN800-SW	800 A	204794	204795
42	DSN1000-SW	1000 A	204804	204805
43	DSN1250-SW	1250 A	204806	204807
44	DSN1600-SW	1600 A	204808	204809

① Reference to breaker specifications on p. 12ff.

Internal Accessories

Modular cassette type accessories

The new arrangement and design of pluggable accessories such as indicator and auxiliary contacts allows you to modify the circuit in a way that saves time and space – at any time, even when built in and ready for operation.

The presence of separate circuit chambers makes the system even safer.

Thus cassette type accessories ensure flexibility when upgrading circuits.

The cassette type accessories are available in several versions and fit for breaker series from 32 A up to 800 A:

- alarm switch (AL)
- auxiliary switch (AX)
- alarm and auxiliary switch (AL+AX)
- shunt trip device (SHT)
- undervoltage trip device (UVT)

with lead-wire terminal block as standard.

In addition you can choose the lead-wire version or the internal terminal type as an option.

Alarm switch (AL)

Provides for indication that the MCCB has tripped.

Auxiliary switch (AX)

Provides for indication of whether the breaker is ON or OFF.

Shunt trip (SHT)

Provides for tripping from a remote location. The control voltage range is 70–100 % of rated voltage.

The shunt trip enables an MCCB to be used in combination with an ELR.

Lead-wire terminal block (SLT)

The terminal block is used for bringing out the connections of the internal accessories.

The cassette type accessories are also available as internal terminal type without terminal block. The connection cables are lead out of the breaker housing in line-side direction. So it is possible to mount several breakers easy side-by-side in a row.

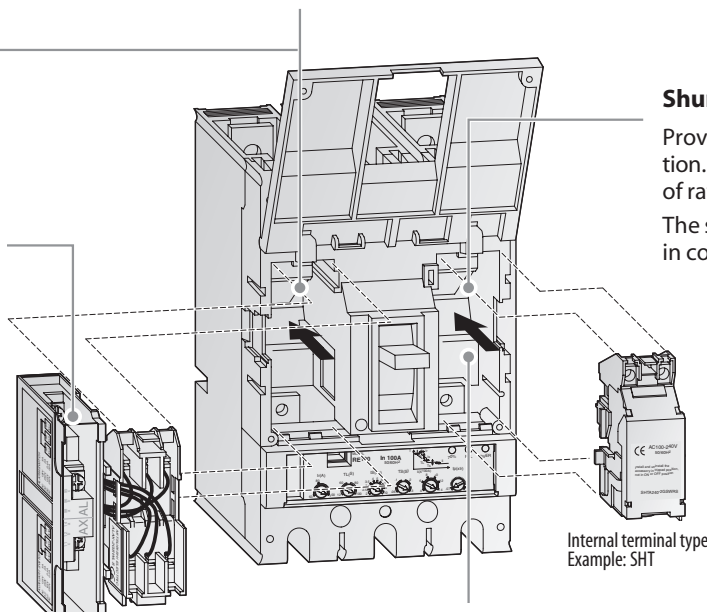

Lead-wire terminal block
Example: ALAX

Internal terminal type
Example: SHT

Undervoltage trip (UVT)

The tripping voltage is 35–70 % of the rated voltage. When the voltage recovers to at least 85 %, the breaker can be manually closed or reset.

Provides for electrical interlock, and is used where electrical machines need to be protected against voltage drop.

For the breakers of the Super Series, 1000 A up to 1600 A, please contact your Distributor.

Overview of Internal Accessories

Cassette-type internal accessory	Function	Catalogue reference
AL (Alarm switch)	The alarm switch AL indicates that the breaker has tripped.	page 26
AX (Auxiliary switch)	The auxiliary switch AX indicates whether the breaker is ON or OFF.	page 26
SHT (Shunt trip)	The shunt trip SHT trips the breaker automatically by remote. A cut-off switch is integrated. The allowable tripping voltage is 70% to 110% of the rated voltage for both AC and DC.	page 28
UVT (Undervoltage trip)	The undervoltage trip UVT trips the breaker automatically when the voltage drops. The tripping voltage is 35% to 70% of the rated voltage. When the voltage recovers to 85% of the rated voltage or above, the UVT can be reset and the breaker closed.	page 30

Connection of the Control Wires

For the connection of the control wires
MITSUBISHI ELECTRIC offers you two ways:

- Lead-wire terminal block (SLT)
- Internal terminal type for direct connection.

Lead-Wire Terminal Block (SLT)

Lead-wire terminal block SLT
with screw terminals

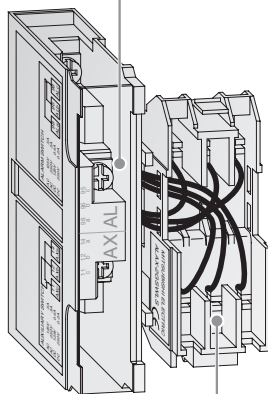

Cassette-type accessory
Example:
ALAX, also for SHT, UVT

Application

All cassette-type accessories are equipped with the Lead-wire terminal block SLT as standard.

The terminal cover for the lead-wire terminals is available for the safety of live parts.

It is available for front connection type, rear connection type and plug-In type.

- Correspondent terminals are not necessary.
- Uneven arrangement of terminal screws is adopted for easier wiring.
- Tightening check of a terminal screw is easy.
- Terminal cover of a terminal block is standard equipment (co-packed).

Internal Terminal Type for Direct Connection

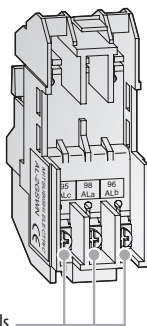

Screw terminals

Example:
AL, also for SHT, UVT

Application

Optional the cassette-type accessories are available as internal terminal type without terminal block.

The control wires can be connected to the integrated screw terminals and can be lead out of the breaker housing in line-side direction.

- Quick install and de-install of the internal accessories is possible without demounting the breaker.
- Mounting of several breakers side-by-side in a row is possible.
- Thus the screw terminals for control wires are inside of the breaker housing, no special terminal cover for the screw terminals is necessary.

Alarm Switch and Auxiliary Switch
(Mounted on left side)

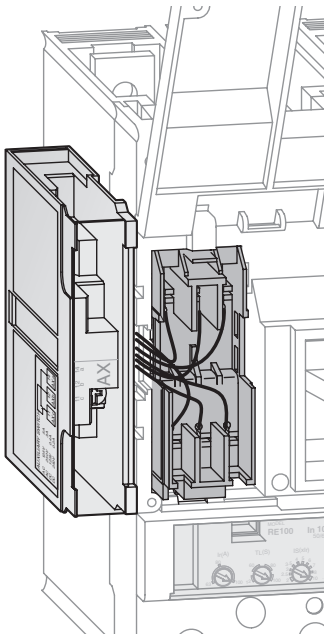

Figure shows Lead-wire terminal block type (SLT).

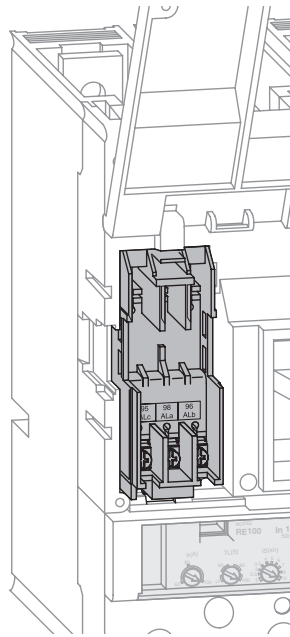

Figure shows Internal terminal type.

Application

The alarm switch AL indicates that the breaker has tripped.
The auxiliary switch AX indicates whether the breaker is ON or OFF.
The alarm and auxiliary switch ALAX is a combination of the alarm switch AL and the auxiliary switch AX in one housing.

- AL, AX and ALAX standard types are for left-side mounting and equipped with lead-wire terminal block SLT.
- Internal terminal type is also available.
- Please specify, if right-side mounted type or type with flying leads is needed.

Contact plans

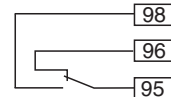

(1 W)
Alarm switch AL

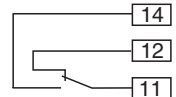

(1 W)
Auxiliary switch AX

Switching Operation

Alarm switch (AL) operation

Main MCCB conditions	Alarm contacts
OFF or ON 	 ALa 98 (open) ALc 95 (closed) (DC+) ^① ALb 96 (closed)
Trip 	 ALa 98 (closed) ALc 95 (open) (DC+) ^① ALb 96 (open)

^① When DC use, polarity must be considered.

Auxiliary switch (AX) operation

Main MCCB conditions	Auxiliary contacts
OFF or Trip 	 AXa 14 (open) AXc 11 (closed) (DC+) ^① AXb 12 (closed)
ON 	 AXa 14 (closed) AXc 11 (open) (DC+) ^① AXb 12 (open)

AL, AX switching capacities

Type of Micro-switch for	Voltage (V AC)	Resistive loads (A)	Inductive load (A)	Voltage (V DC) ^①	Resistive loads (A)	Inductive load (A)
AL/AX/ALAX-05-8	460	—	—	250	0.2	0.2
	250	3	2	125	0.4	0.4
	125	5	3	30	4	3
AL/AX/ALAX-10	460	5	2	250	0.3	0.3
	250	10	10	125	0.6	0.6
	125	10	10	30	10	6

^① When DC use, polarity must be considered.

Order Information for Alarm Switch and Auxiliary Switch

Type	Contacts	Breaker type	Mounted on	Art. no.
Alarm switch AL with lead-wire terminal block SLT				
AL-05SWLS	1 W	NF/DSN32-63	Left side	146379
AL-2GSWLS	1 W	NF/DSN125-250		139505
AL-4SWLS	1 W	NF/DSN400-800		205763
AL2-4SWLS	2 W			205764
AL3-8SWLS	3 W	NF/DSN800		205765
AL-10SWL	1 W	NF/DSN1000-1600		205766

Alarm switch AL for direct connection

AL-2GSWN	1 W + 1 W	NF/DSN125-250	Left side	139508
----------	-----------	---------------	-----------	--------

Auxiliary switch AX with lead-wire terminal block SLT

AX-05SWLS	1 W	NF/DSN32-63	Left side	146380
AX2-05SWLS	2 W			146382
AX-2GSWLS	1 W	NF/DSN125-250		139504
AX2-2GSWLS	2 W			139506
AX-4SWLS	1 W	NF/DSN400-800		205767
AX2-4SWLS	2 W			205768
AX3-8SWLS	3 W	NF/DSN800	205769	
AX4-8SWLS	4 W	NF400-UEW 4P	205770	
AX-10SWLS	1 W	NF/DSN1000-1600	205771	
AX2-10SWLS	2 W		205772	
AX3-10SWLS	3 W		205773	

Auxiliary switch AX for direct connection

AX-2GSWN	1 W	NF/DSN125-250	Left side	139507
AX2-2GSWLN	2 W			139510

Type	Contacts AL AX	Breaker type	Mounted on	Art. no.
Alarm switch and Auxiliary switch ALAX with lead-wire terminal block SLT				
ALAX-05SWLS	1 W + 1 W	NF/DSN32-63	Left side	146381
ALAX-2GSWLS	1 W + 1 W	NF/DSN125-250		137510
ALAX-4SWLS	1 W + 1 W	NF/DSN400-800 NF400-UEW 4P		205774
AL2AX2-4SWLS	2 W + 2 W			205775
ALAX-10SWL	1 W + 1 W	NF/DSN1000-1600		205776
AL1AX2-10SWL	1 W + 2 W			205777

Alarm switch and Auxiliary switch ALAX for direct connection

ALAX-2GSWN	1 W + 1 W	NF/DSN125-250	Left side	139509
------------	-----------	---------------	-----------	--------

Shunt Trip Device SHT

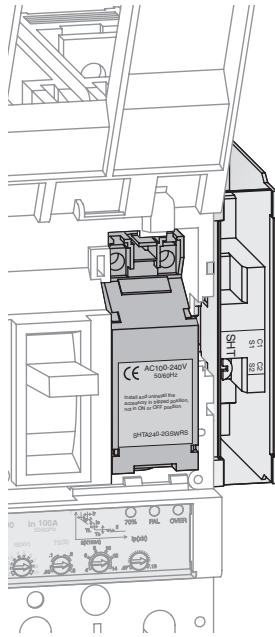

Figure shows Lead-wire terminal block type (SLT).

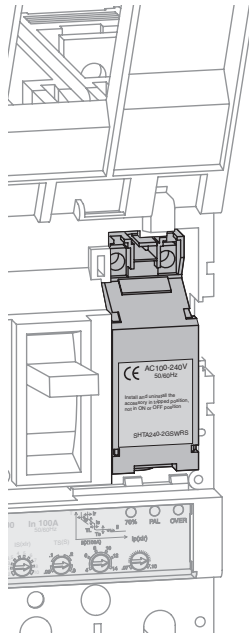

Figure shows Internal terminal type.

Application

The shunt trip device SHT trips the breaker automatically by remote. A cut-off switch is integrated.

The allowable tripping voltage range is 70% to 110% of the rated voltage for both AC and DC.

The SHT is mounted on the right side of the breaker and equipped with lead-wire terminal block SLT as standard.

Please specify, if left-side mounted type or type with flying leads is needed (optional available).

Please consider, the shunt trip device SHT for 3-pole and 4-pole breakers is different in the length of wires based on the outline dimension of the breaker.

Contact plan

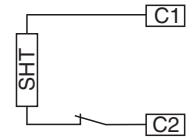

With cut-off switch

Coil ratings

MCCB type ^①	Cut-off switch	Voltage (V) ^②	Input ^③ AC (VA)	DC (W)	Operating time (msec) ^④
NF32-SW NF63-SW NF63-HW	Equipped			50	
NF125-SGW RT/RE NF125-HGW RT/RE NF125-RGW RT/UGW RT NF160-SGW RT/RE NF160-HGW RT/RE NF250-SGW RT/RE NF250-HGW RT/RE NF250-RGW RT/UGW RT	Equipped	AC 24-48 AC 100-240 AC 380-550 (50 / 60 Hz) DC 100-125	120	60	≤15
NF400-SEW / HEW / REW / UEW NF630-SEW / HEW / REW NF800-CEW / SEW / HEW / REW / UEW	Equipped	AC 24-48 / DC 24-48 AC 100-450 / DC 100-200 AC 380-550 (50 / 60 Hz)	100 V: 20 200 V: 50 330 V: 120 450 V: 170	100 V: 10 200 V: 35	5-15
NF1000-SEW NF1250-SEW NF1600-SEW	Equipped	AC 100-120 AC 200-240 AC 380-450 (50 / 60Hz) DC 100	200	70	7-15

① Also for DSN types.

② Other voltages on request

③ For the SHT operating power capacity, any voltage drop in the input electric power must not be below the allowable operating voltage range.

④ The operating time includes all the time up to the moment the main contact of the breaker disconnects after a voltage has been applied to the shunt trip devices.

Order Information for Shunt Trip Devices SHT

With lead-wire terminal block SLT, mounted on right-side

For 3-pole breaker			For 4-pole breaker			Rated voltage
Type	Breaker type	Art. no.	Type	Breaker type	Art. no.	
SHTA048-05SWRS	NF/DSN32-63	146383	SHTA048-05SWRFS	NF/DSN32-63	146384	AC 24-48 V
SHTA240-05SWRS		146385	SHTA240-05SWRFS		146386	AC 100-240 V
SHTA550-05SWRS		146387	SHTA550-05SWRFS		146388	AC 380-550 V
SHTD012-05SWRS		146389	SHTD012-05SWRFS		146390	DC 12 V
SHTD036-05SWRS		146391	SHTD036-05SWRFS		146392	DC 24-36 V
SHTD048-05SWRS		146393	SHTD048-05SWRFS		146394	DC 36-48 V
SHTD125-05SWRS		146395	SHTD125-05SWRFS		146396	DC100-125 V
SHTD250-05SWRS		146397	SHTD250-05SWRFS		146398	DC220-250 V
SHTA048-2GSWRS		NF/DSN125-250	139513		SHTA048-2GSWRFS	NF/DSN125-250
SHTA240-2GSWRS	139515		SHTA240-2GSWRFS	139516	AC 100-240 V	
SHTA550-2GSWRS	139517		SHTA550-2GSWRFS	139518	AC 380-550 V	
SHTD012-2GSWRS	139519		SHTD012-2GSWRFS	139520	DC 12 V	
SHTD036-2GSWRS	139521		SHTD036-2GSWRFS	139522	DC 24-36 V	
SHTD048-2GSWRS	139523		SHTD048-2GSWRFS	139524	DC 36-48 V	
SHTD125-2GSWRS	139525		SHTD125-2GSWRFS	139526	DC100-125 V	
SHTD250-2GSWRS	139527		SHTD250-2GSWRFS	139528	DC220-250 V	
SHT-4SWRS	NF/DSN400-800		205778	SHT-4SWRFS	NF/DSN400-630	
SHT48-4SWRS		205780	SHT48-4SWRFS	205781		AC 24-48 V / DC 24-48 V
SHTA550-4SWRS		205782	SHTA550-4SWRFS	205783		AC 380-550 V
—	—	—	SHT-8SWRFS	NF/DSN800 NF400-UEW 4P	205784	AC 100-450 V / DC100-200 V
—	—	—	SHT48-8SWRFS		205785	AC 24-48 V / DC 24-48 V
—	—	—	SHTA550-8SWRFS		205786	AC 380-550 V
SHTA120-10SWRS	NF/DSN1000-1600	205787	SHTA120-10SWRFS	NF/DSN1000-1600	205788	AC 100-120 V, 50/60 Hz
SHTA240-10SWRS		205789	SHTA240-10SWRFS		205790	AC 200-240 V, 50/60 Hz
SHTA450-10SWRS		205791	SHTA450-10SWRFS		205792	AC 380-450 V, 50/60 Hz
SHTD024-10SWRS		205793	SHTD024-10SWRFS		205794	DC 24 V
SHTD110-10SWRS		205795	SHTD110-10SWRFS		205796	DC 110 V

For direct connection, mounted on right-side

For 3-/4-pole breaker			
Type	Breaker type	Rated voltage	Art. no.
SHTA048-2GSWRN	NF/DSN125-250	AC 24-48 V	139529
SHTA240-2GSWRN		AC 100-240 V	139530
SHTA550-2GSWRN		AC 380-550 V	139531
SHTD012-2GSWRN		DC 12 V	139532
SHTD036-2GSWRN		DC 24-36 V	139533
SHTD048-2GSWRN		DC 36-48 V	139534
SHTD125-2GSWRN		DC 100-125 V	139535
SHTD250-2GSWRN		DC 220-250 V	139536

Undervoltage Tripping Device UVT

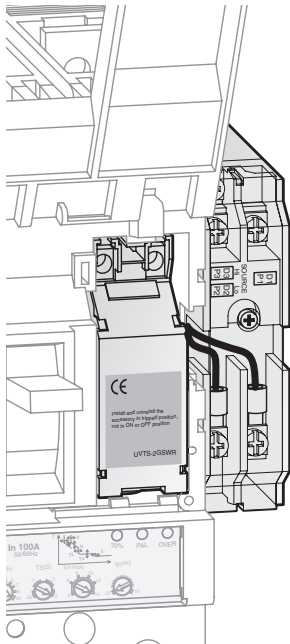

Figure shows Lead-wire terminal block type (SLT).

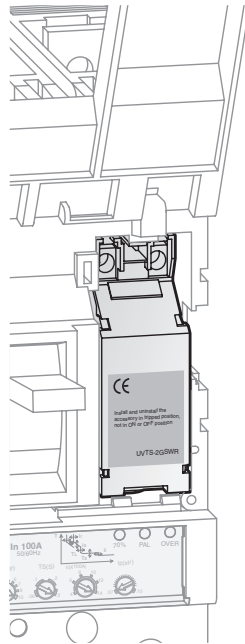

Figure shows Internal terminal type.

Application

The undervoltage tripping device UVT trips the breaker automatically when the voltage drops. The tripping voltage is 35% to 70% of the rated voltage. When the voltage recovers to 85% of the rated voltage or above, the UVT can be reset and the breaker closed.

The UVT is mounted on the right side of the breaker and equipped with lead-wire terminal block SLT as standard.

Please specify, if left-side mounted type or type with flying leads is needed.

Please consider, the undervoltage trip UVT for 3-pole and 4-pole breaker is different in the length of wires based on the outline dimension of the breaker.

Contact plan

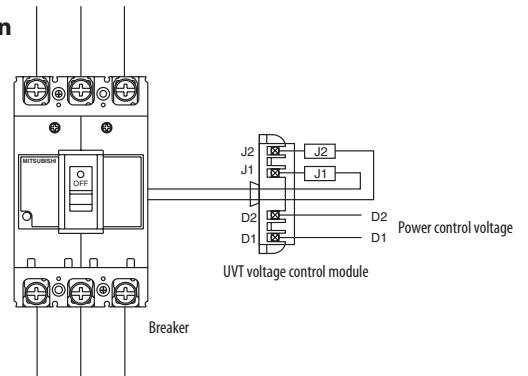

Coil ratings

Breaker type ①	For synchronous closing	Voltage (V) ② Standard	Input (VA)	Operating time ③ (msec)	Making/breaking data	
					Breaker OFF	Breaker ON
NF32-SW NF63-SW NF125-SGW RT/RE NF125-HGW RT/RE NF125-RGW RT/UGW RT NF160-SGW RT/RE NF160-HGW RT/RE NF250-SGW RT/RE NF250-HGW RT/RE NF250-RGW RT/UGW RT	●	AC 100–120 AC 200–240 AC 220–240 AC 380–450 AC 400–440 (50 / 60 Hz) DC 24, DC 110	5	≤ 30	35–70 % U _N	min. 85 % U _N
NF400-SEW / HEW / REW / UEW NF630-SEW / HEW / REW NF800-CEW / SEW / HEW / REW / UEW	●	AC 100–110/120–130 AC 200–220/230–250 AC 380–415/440–480 (50 / 60 Hz) DC100/110		5–30 (Instantaneous type)		
NF1000-SEW NF1250-SEW NF1600-SEW	—④	AC 100–120/200–240/380–450 AC 200–250/380–450/460–550 (50 / 60 Hz)		5–35 (Time delay type with 3 voltage inputs)		

① Also for DSN types.
 ② Other voltages on request.
 ③ The operating time is the time from the start of operating the breaker since the undervoltage trip went from voltage to no-voltage condition.
 ④ On request, please see page 31.
 UVTs with Time delay on request.

Types of UVTs

Breaker type	No. of Poles	Rated voltages						
		AC 24 / 48 V	AC 100–110 V / AC 120–130 V	AC 200–220 V / AC 230–250 V	AC 380–415 V / AC 440–480 V	AC 500–550 V / AC 600 V	DC 24 / 48 V	DC 100 / 110 V

Instantaneous trip type, with lead-wire terminal block SLT

NF/DSN32–63	3	UVTNA048-05SWRS	UVTNA130-05SWRS	UVTNA250-05SWRS	UVTNA480-05SWRS	UVTNA600-05SWRS	UVTND048-05SWRS	UVTND110-05SWRS	UVTND125-05SWRS
	4	UVTNA048-05SWRFS	UVTNA130-05SWRFS	UVTNA250-05SWRFS	UVTNA480-05SWRFS	UVTNA600-05SWRFS	UVTND048-05SWRFS	UVTND110-05SWRFS	UVTND125-05SWRFS
NF/DSN125–250	3	UVTSA048-2GSWRS	UVTSA130-2GSWRS	UVTSA250-2GSWRS	UVTSA480-2GSWRS	UVTSA600-2GSWRS	UVTSD048-2GSWRS	UVTSD110-2GSWRS	UVTSD125-2GSWRS
	4	UVTSA048-2GSWRF5	UVTSA130-2GSWRF5	UVTSA250-2GSWRF5	UVTSA480-2GSWRF5	UVTSA600-2GSWRF5	UVTSD048-2GSWRF5	UVTSD110-2GSWRF5	UVTSD125-2GSWRF5

Instantaneous trip type, for direct connection

NF/DSN125–250	3/4	UVTSA048-2GSWRN	UVTSA130-2GSWRN	UVTSA250-2GSWRN	UVTSA480-2GSWRN	UVTSA600-2GSWRN	UVTSD048-2GSWRN	UVTSD110-2GSWRN	UVTSD125-2GSWRN
---------------	-----	-----------------	-----------------	-----------------	-----------------	-----------------	-----------------	-----------------	-----------------

Breaker type	No. of Poles	Rated voltages				
		AC 100–110 V / AC 120–130 V	AC 200–220 V / AC 230–250 V	AC 380–415 V / AC 440–480 V	DC 24 / 48 V	DC 100 / 110 V

Instantaneous trip type, with lead-wire terminal block SLT

NF/DSN400–800	3	UVTSA130-4SWS	UVTSA250-4SWS	UVTSA480-4SWS	UVTSD048-4SWS	UVTSD110-4SWS
NF/DSN400–630	4	UVTSA130-4SWRFS	UVTSA250-4SWRFS	UVTSA480-4SWRFS	UVTSD048-4SWRFS	UVTSD110-4SWRFS
NF/DSN800	4	UVTSA130-8SWRFS	UVTSA250-8SWRFS	UVTSA480-8SWRFS	UVTSD048-8SWRFS	UVTSD110-8SWRFS
NF/DSN1000–1600	3	UVTSA130-10SWRS	UVTSA250-10SWRS	UVTSA480-10SWRS	UVTND048-10SWRS	UVTND110-10SWRS
	4	UVTSA130-10SWRFS	UVTSA250-10SWRFS	UVTSA480-10SWRFS	UVTND048-10SWRFS	UVTND110-10SWRFS

Breaker type	No. of Poles	Rated voltages				
		AC 24 / 48 V	AC 100–120 V / AC 200–240 V / AC 380–450 V	AC 200–250 V / AC 380–450 V / AC 460–550 V	AC 380–450 V / AC 460–550 V / AC 600–690 V	DC 24 / 48 V

Short-time delay type, with lead-wire terminal block SLT, short-time delay adjustable in steps 0.1–0.3–0.5 sec

NF/DSN32–63	3	UVTNA048-05SWRSU05	UVTNA450-05SWRSU05	UVTNA550-05SWRSU05	UVTNA690-05SWRSU05	UVTND048-05SWRSU05	UVTND110-05SWRSU05
	4	UVTNA048-05SWRFSU05	UVTNA450-05SWRFSU05	UVTNA550-05SWRFSU05	UVTNA690-05SWRFSU05	UVTND048-05SWRFSU05	UVTND110-05SWRFSU05
NF/DSN125–250	3	UVTSA048-2GSWRSU05	UVTSA450-2GSWRSU05	UVTSA550-2GSWRSU05	UVTSA690-2GSWRSU05	UVTSD048-2GSWRSU05	UVTSD110-2GSWRSU05
	4	UVTSA048-2GSWRF5U05	UVTSA450-2GSWRF5U05	UVTSA550-2GSWRF5U05	UVTSA690-2GSWRF5U05	UVTSD048-2GSWRF5U05	UVTSD110-2GSWRF5U05

Short-time delay type, for direct connection, short-time delay adjustable in steps 0.1–0.3–0.5 sec

NF/DSN125–250	3/4	UVTSA048-2GSWRNU05	UVTSA450-2GSWRNU05	UVTSA550-2GSWRNU05	UVTSA690-2GSWRNU05	UVTSD048-2GSWRNU05	UVTSD110-2GSWRNU05
---------------	-----	--------------------	--------------------	--------------------	--------------------	--------------------	--------------------

Breaker type	No. of Poles	Rated voltages	
		AC 100–120 / 200–240 / 380–450 V	AC 200–250 / 380–450 / 460–550 V

Long-time delay type, with lead-wire terminal block SLT, long-time delay adjustable in steps 0.5–1.0–3.0 sec

NF/DSN32–63	3	UVTNA450-05SWRSU30	UVTNA550-05SWRSU30
	4	UVTNA450-05SWRFSU30	UVTNA550-05SWRFSU30
NF/DSN125–250	3	UVTSA450-2GSWRSU30	UVTSA550-2GSWRSU30
	4	UVTSA450-2GSWRF5U30	UVTSA550-2GSWRF5U30

Long-time delay type, for direct connection, long-time delay adjustable in steps 0.5–1.0–3.0 sec

NF/DSN125–250	3/4	UVTSA450-2GSWRNU30	UVTSA550-2GSWRNU30
---------------	-----	--------------------	--------------------

Order Information for Undervoltage Tripping Devices UVT

Undervoltage tripping device UVT, instantaneous trip type, synchronous closing, mounted on right-side

with lead-wire terminal block SLT, for 3-pole breakers

Type	Breaker type	Rated voltage	Art. no.
UVTNA048-05SWRS	NF/DSN32-63	AC 24 / 48 V	146399
UVTNA130-05SWRS		AC 100-110 / 120-130 V	146401
UVTNA250-05SWRS		AC 200-220 / 230-250 V	146403
UVTNA480-05SWRS		AC 380-415 / 440-480V	146405
UVTNA600-05SWRS		AC 500-550 / 600 V	146407
UVTND048-05SWRS		DC 24 / 48 V	146409
UVTND125-05SWRS		DC 110 / 125 V	146411

UVTSA048-2GSWRS	NF/DSN125-250	AC 24 / 48 V	139537
UVTSA130-2GSWRS		AC 100-110 / 120-130 V	139539
UVTSA250-2GSWRS		AC 200-220 / 230-250 V	139541
UVTSA480-2GSWRS		AC 380-415 / 440-480V	139543
UVTSA600-2GSWRS		AC 500-550 / 600 V	139545
UVTSD048-2GSWRS		DC 24 / 48 V	139547
UVTSD110-2GSWRS		DC 100 / 110 V	139548
UVTSD125-2GSWRS		DC 110 / 125 V	139550

UVTSA130-4SWS	NF/DSN400-800	AC 100-110 / 120-130 V	205951
UVTSA250-4SWS		AC 200-220 / 230-250 V	205953
UVTSA480-4SWS		AC 380-415 / 440-480V	205828
UVTSD048-4SWS		DC 24 / 48 V	205932
UVTSD110-4SWS		DC 100 / 110 V	205934

UVTSA130-10SWRS	NF/DSN1000-1600	AC 100-110 / 120-130 V	205941
UVTSA250-10SWRS		AC 200-220 / 230-250 V	205943
UVTSA480-10SWRS		AC 380-415 / 440-480V	205945
UVTND048-10SWRS		DC 24 / 48 V	205947
UVTND110-10SWRS		DC 100 / 110 V	205949

with lead-wire terminal block SLT, for 4-pole breakers

Type	Breaker type	Rated voltage	Art. no.
UVTNA048-05SWRFS	NF/DSN 63	AC 24 / 48 V	146400
UVTNA130-05SWRFS		AC 100-110 / 120-130 V	146402
UVTNA250-05SWRFS		AC 200-220 / 230-250 V	146404
UVTNA480-05SWRFS		AC 380-415 / 440-480V	146406
UVTNA600-05SWRFS		AC 500-550 / 600 V	146408
UVTND048-05SWRFS		DC 24 / 48 V	146410
UVTND125-05SWRFS		DC 110 / 125 V	146412

UVTSA048-2GSWRFSS	NF/DSN125-250	AC 24 / 48 V	139538
UVTSA130-2GSWRFSS		AC 100-110 / 120-130 V	139540
UVTSA250-2GSWRFSS		AC 200-220 / 230-250 V	139542
UVTSA480-2GSWRFSS		AC 380-415 / 440-480 V	139544
UVTSA600-2GSWRFSS		AC 500-550 / 600 V	139546
UVTSD048-2GSWRFSS		DC 24 / 48 V	137508
UVTSD110-2GSWRFSS		DC 100 / 110 V	139549
UVTSD125-2GSWRFSS		DC 110 / 125 V	139551

UVTSA130-4SWRFS	NF/DSN400-630	AC 100-110 / 120-130 V	205952
UVTSA250-4SWRFS		AC 200-220 / 230-250 V	205954
UVTSA480-4SWRFS		AC 380-415 / 440-480 V	205955
UVTSD048-4SWRFS		DC 24 / 48 V	205933
UVTSD110-4SWRFS		DC 100 / 110 V	205935

UVTSA130-8SWRFS	NF/DSN800	AC 100-110 / 120-130 V	205936
UVTSA250-8SWRFS		AC 200-220 / 230-250 V	205937
UVTSA480-8SWRFS		AC 380-415 / 440-480 V	205938
UVTSD048-8SWRFS		DC 24 / 48 V	205939
UVTSD110-8SWRFS		DC 100 / 110 V	205940

UVTSA130-10SWRFS	NF/DSN1000-1600	AC 100-110 / 120-130 V	205942
UVTSA240-10SWRFS		AC 200-220 / 230-250 V	205944
UVTSA480-10SWRFS		AC 380-415 / 440-480 V	205946
UVTND048-10SWRFS		DC 24 / 48 V	205948
UVTND110-10SWRFS		DC 100 / 110 V	205950

for direct connection, for 3- and 4-pole breakers

Type	Breaker type	Rated voltage	Art. no.
UVTSA048-2GSWRN	NF/DSN125-250	AC 24 / 48 V	139552
UVTSA130-2GSWRN		AC 100-110 / 120-130 V	139553
UVTSA250-2GSWRN		AC 200-220 / 230-250 V	139554
UVTSA480-2GSWRN		AC 380-415 / 440-480 V	139555
UVTSA600-2GSWRN		AC 500-550 / 600 V	139556
UVTSD048-2GSWRN		DC 24 / 48 V	139557
UVTSD110-2GSWRN		DC 100 / 110 V	139558
UVTSD125-2GSWRN		DC 110 / 125 V	139559

Order Information for Undervoltage Tripping Devices UVT

Undervoltage tripping device UVT, short-time delay type, adjustable in steps 0.1–0.3–0.5 sec, mounted on right-side with lead-wire terminal block SLT, for 3-pole breakers

Type	Breaker type	Rated voltage	Art. no.
UVTNA048-05SWRSU05	NF/DSN32–63	AC 24 / 48 V	146413
UVTNA450-05SWRSU05		AC 100–120 / 200–240 / 380–450 V	146425
UVTNA550-05SWRSU05		AC 200–250 / 380–450 / 460–550 V	146427
UVTNA690-05SWRSU05		AC 380–450 / 460–550 / 600–690 V	146429
UVTND048-05SWRSU05		DC 24 / 48 V	146431
UVTND110-05SWRSU05		DC 100–110 V	146433
UVTSA048-2GSWRSU05	NF/DSN125–250	AC 24 / 48 V	139560
UVTSA450-2GSWRSU05		AC 100–120 / 200–240 / 380–450 V	139562
UVTSA550-2GSWRSU05		AC 200–250 / 380–450 / 460–550 V	139564
UVTSA690-2GSWRSU05		AC 380–450 / 460–550 / 600–690 V	139566
UVTSD048-2GSWRSU05		DC 24 / 48 V	139568
UVTSD110-2GSWRSU05		DC 100 / 110 V	139569
UVTSA450-4SWSU05	NF/DSN400–630	AC 100–120 / 200–240 / 380–450 V	205818
UVTSD048-4SWSU05		DC 24 / 48 V	205838
UVTSD110-4SWSU05		DC 100 / 110 V	205842
UVTSA450-10SWRU05	NF/DSN1000–1600	AC 100–120 / 200–240 / 380–450 V	205856
UVTSA550-10SWRU05		AC 200–250 / 380–450 / 460–550 V	205868
UVTND048-10SWRU05		DC 24 / 48 V	205876
UVTND110-10SWRU05		DC 100 / 110 V	205880

with lead-wire terminal block SLT, for 4-pole breakers

Type	Breaker type	Rated voltage	Art. no.
UVTNA048-05SWRFSU05	NF/DSN32–63	AC 24 / 48 V	146424
UVTNA450-05SWRFSU05		AC 100–120 / 200–240 / 380–450 V	146426
UVTNA550-05SWRFSU05		AC 200–250 / 380–450 / 460–550 V	146428
UVTNA690-05SWRFSU05		AC 380–450 / 460–550 / 600–690 V	146430
UVTND048-05SWRFSU05		DC 24 / 48 V	146432
UVTND110-05SWRFSU05		DC 100–110 V	146434
UVTSA048-2GSWRFU05	NF/DSN125–250	AC 24 / 48 V	139561
UVTSA450-2GSWRFU05		AC 100–120 / 200–240 / 380–450 V	139563
UVTSA550-2GSWRFU05		AC 200–250 / 380–450 / 460–550 V	139565
UVTSA690-2GSWRFU05		AC 380–450 / 460–550 / 600–690 V	139567
UVTSD048-2GSWRFU05		DC 24 / 48 V	137509
UVTSD110-2GSWRFU05		DC 100 / 110 V	139570
UVTSA450-4SWRFSU05	NF/DSN400–630	AC 100–120 / 200–240 / 380–450 V	205819
UVTSD048-4SWRFSU05		DC 24 / 48 V	205839
UVTSD110-4SWRFSU05		DC 100 / 110 V	205843
UVTSA450-8SWRFSU05	NF/DSN800	AC 100–120 / 200–240 / 380–450 V	205845
UVTSD048-8SWRFSU05		DC 24 / 48 V	205852
UVTSD110-8SWRFSU05		DC 100 / 110 V	205854
UVTSA450-10SWRFU05	NF/DSN1000–1600	AC 100–120 / 200–240 / 380–450 V	205858
UVTSA550-10SWRFU05		AC 200–250 / 380–450 / 460–550 V	205872
UVTND048-10SWRFU05		DC 24 / 48 V	205878
UVTND110-10SWRFU05		DC 100 / 110 V	205882

for direct connection, for 3- and 4-pole breakers

Type	Breaker type	Rated voltage	Art. no.
UVTSA048-2GSWRNU05	NF/DSN125–250	AC 24 / 48 V	139571
UVTSA450-2GSWRNU05		AC 100–120 / 200–240 / 380–450 V	139572
UVTSA550-2GSWRNU05		AC 200–250 / 380–450 / 460–550 V	139573
UVTSA690-2GSWRNU05		AC 380–450 / 460–550 / 600–690 V	139574
UVTSD048-2GSWRNU05		DC 24 / 48 V	139575
UVTSD110-2GSWRNU05		DC 100–110 V	139576

Undervoltage tripping device UVT, long-time delay type, adjustable in steps 0.5–1.0–3.0 sec, mounted on right-side

with lead-wire terminal block SLT, for 3-pole breakers

Type	Breaker type	Rated voltage	Art. no.
UVTNA450-05SWRSU30	NF/DSN32–63	AC 100–120 / 200–240 / 380–450 V	146435
UVTNA550-05SWRSU30		AC 200–250 / 380–450 / 460–550 V	146437
UVTSA450-2GSWRSU30	NF/DSN125–250	AC 100–120 / 200–240 / 380–450 V	139577
UVTSA550-2GSWRSU30		AC 200–250 / 380–450 / 460–550 V	139579
UVTSA450-4SWSU30	NF/DSN400–800	AC 100–120 / 200–240 / 380–450	205826
UVTSA550-10SWRU30	NF/DSN1000–1600	AC 200–250 / 380–450 / 460–550 V	205870

with lead-wire terminal block SLT, for 4-pole breakers

Type	Breaker type	Rated voltage	Art. no.
UVTNA450-05SWRFSU30	NF/DSN32–63	AC 100–120 / 200–240 / 380–450 V	146436
UVTNA550-05SWRFSU30		AC 200–250 / 380–450 / 460–550 V	146438
UVTSA450-2GSWRFU30	NF/DSN125–250	AC 100–120 / 200–240 / 380–450 V	139578
UVTSA550-2GSWRFU30		AC 200–250 / 380–450 / 460–550 V	139580
UVTSA450-4SWRFSU30	NF/DSN400–630	AC 100–120 / 200–240 / 380–450	205827
UVTSA450-8SWRFSU30	NF/DSN800	AC 100–120 / 200–240 / 380–450	205849
UVTSA450-10SWRFU30	NF/DSN1000–1600	AC 100–120 / 200–240 / 380–450	205866
UVTSA550-10SWRFU30		AC 200–250 / 380–450 / 460–550 V	205874

for direct connection, for 3- and 4-pole breakers

Type	Breaker type	Rated voltage	Art. no.
UVTSA450-2GSWRNU30	NF/DSN125–250	AC 100–120 / 200–240 / 380–450 V	139581
UVTSA550-2GSWRNU30		AC 200–250 / 380–450 / 460–550 V	139582

Accessories for Connection and Installation

If no connection method is specified with the order, we deliver the standard fixed-installation type with front connection.

The front-connection model can be modified to other types (excluding plug-in) with special purchase options.

More details on request.

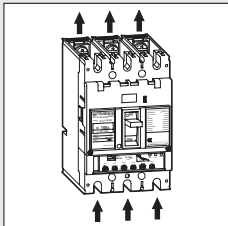
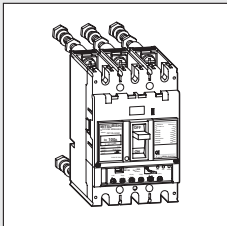
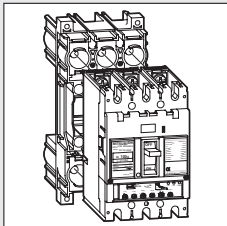
Connection Types			
Installation	Fixed		Plug-in
Connection	Front (F)	Rear (B)	Rear (PM)
Appearance			
	Standard	Option	Option

Available Terminal Connections

Frame size	Front (Standard)	Rear	Solderless terminals	Plug-in
32–250 A	●	●	● ^①	●
400–800 A	●	●	—	●
1000–1600 A	●	— ^②	—	— ^②

① Only for frame sizes 125/160/250 A

② On request, modified at factory.

Connection Accessories

Rear studs ST

Type	No. of Poles	Breaker type	Art. no.
ST-05SW3	3	NF/DSN32–63	146441
ST-05SW4	4		146442
ST-2GSW3	3	NF/DSN125–250	139591
ST-2GSW4	4		139592
ST-4SW3	3	NF/DSN400	205956
ST-4SW4	4		205957
ST-6SW3	3	NF/DSN630	205958
ST-6SW4	4		205959
ST-8SW3	3	NF/DSN800	205960
ST-8SW4	4		205961

Plug-in sets PM

Type	No. of Poles	Breaker type	Protection degree	Art. no.
PM-05SW3	3	NF/DSN32–63	—	146443
PM-05SW4	4			146444
PM-2GSWIP3	3	NF/DSN125–250	IP 20	137511
PM-2GSWIP4	4			137512
PM-4SW3	3	NF/DSN400	—	205962
PM-4SW4	4			205963
PM-6SW3	3	NF/DSN630	—	205964
PM-6SW4	4			205965
PM-8SW3	3	NF/DSN800	—	205966
PM-8SW4	4			205967

Solderless terminals SL

Type	No. of Poles	Breaker type	Art. no.	Packing unit	Connected wire size	Used for
SL-2GSW3	3	NF/DSN125–250	139593	1 Set = 3 pcs.	2.5–185 mm ²	Cu/Al
SL-2GSW4	4		139594	1 Set = 4 pcs.		

More types available on request.

V-Type Operating Handle

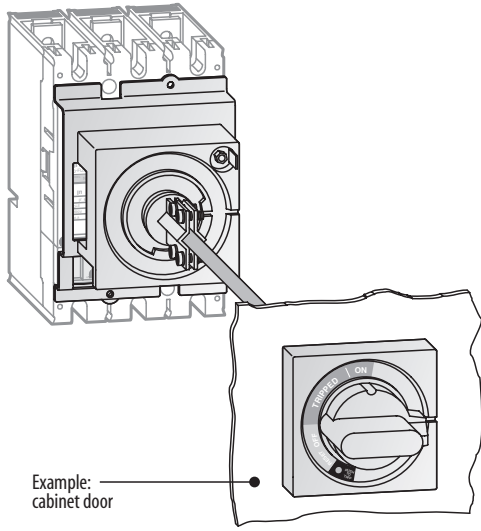

Application

The V-type operating handle is used to operate the breaker which is installed in a cabinet. With the installed V-type operating handle the breaker can be locked (with up to 3 padlocks, Ø 8 mm max., padlocks are not included) in OFF position only.

The door is locked when the breaker is ON and can only be opened when the breaker is in OFF position.

The V-type operating handle is available in the following colour combinations:

Handle and front in black/black and handle and front in red/yellow, or red/black, see also the following table.

- Protection degree (in accord. to IEC/EN 60 529): see table below.
- Variable axle length.

Specifications	V-type operating handle											
	V05SWN	V05SWEN	V2GSWN	V2GSWEN	V2GUWN	V2GUWEN	V4SW	V4SWE	V8SW	V8SWE	V101	V101E
Breaker type	NF/DSN32-63		NF/DSN125/160/250-SGW/HGW		NF125/250-RGW/UGW		NF/DSN400-630		NF/DSN800		NF/DSN1000-1600	
Colour: handle/front	black	red/yellow	black	red/yellow	black	red/yellow	black	red/yellow	black	red/yellow	black	red/black
Protection degree	IP65	IP65	IP65	IP65	IP65	IP65	IP65	IP65	IP65	IP65	IP50	IP50
Art. no.	146457	146458	137513	139627	139626	139628	203761	203762	203763	203764	11659	11663

R-Type Operating Handle

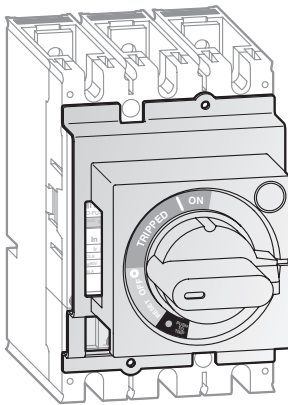

Application

The R-type operating handle is to be mounted directly on the breaker.

With the installed R-type operating handle the breaker can be locked (with up to 3 padlocks, Ø 8 mm max., padlocks are not included) in OFF position only.

The R-type operating handle is available in the following colour combinations:

Handle and front in black/black and handle and front in red/yellow, or red/black, see also the following table.

Specifications	R-type operating handle									
	R2GSWN	R2GSWEN	R2GUWN	R2GUWEN	R4SW	R4SWE	R8SW	R8SWE	R101	R101E
Breaker type	NF/DSN125/160/250-SGW/HGW		NF125/250-RGW/UGW		NF/DSN400-630		NF/DSN800		NF/DSN1000-1600	
Colour: handle/front	black	red/yellow	black	red/yellow	black	red/yellow	black	red/yellow	black	red/black
Art. no.	139622	139624	139623	139625	203765	203766	203767	203769	11620	11623

Handle Lock Devices

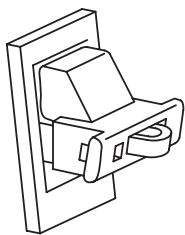

LC-2G5W

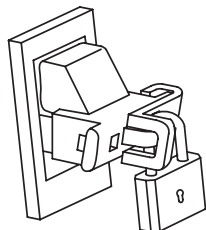

HLF-2G5W

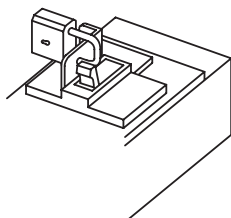

HLS-2G5W

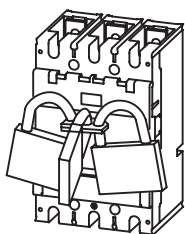

HLF3-2G5W

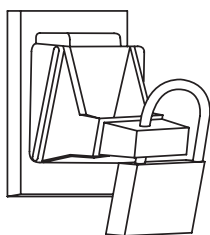

HL-4SW

Application

The handle lock device HL is used to lock the handle of the breaker against switching by not-allowed persons. The function of protection is given every time.

Different types are available.

- All handle lock devices can be mounted regardless of the number of poles.
- Padlocks are not included.
- More details on request.

Handle lock device LC type

- The handle lock can be used without padlock as a lock cover.

Handle lock device HL type

- The handle lock HL type can be used for 3- and 4-pole breaker types.
- The handle locks can be used without padlock as lock covers.
- The HLF types are used for OFF-lock and the HLN types are used for ON-lock.
- The handle lock HLF3 type enables the user to lock the handle with up to three padlocks against switching.
- The HLS types are used for OFF-lock only.

Type	Breaker type	Art. no.
LC-05SW	NF/DSN32-63	146453
LC-2G5W	NF/DSN125-250	139613
HLF-05SW	NF/DSN32-63	146454
HLF-2G5W	NF/DSN125-250	139614
HLF3-2G5W	NF/DSN125-250	139615
HLN-05SW	NF/DSN32-63	146455
HLN-2G5W	NF/DSN125-250	139616
HLS-05SW	NF/DSN32-63	146456
HLS-2G5W	NF/DSN125-250	139617
HL-4SW	NF/DSN400-800	205975
HL-10SW	NF/DSN100-1600	205976

Electrically Operated Breakers – Overview

Spring-charged types MDS

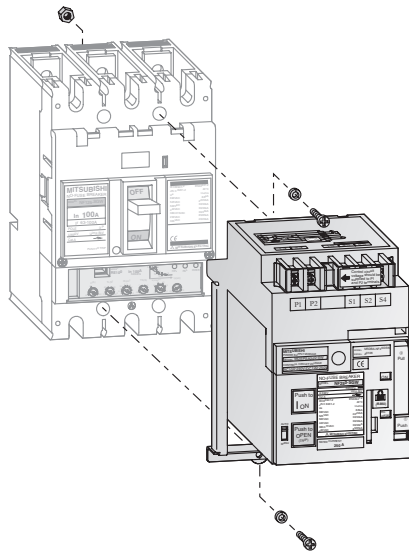

Spring-charged type MDSAD240-NF2GSWE and breaker type NF250-SGW

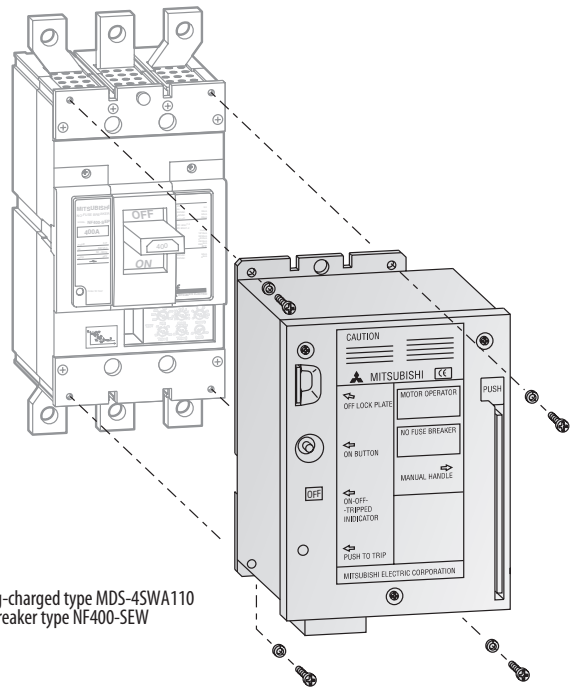

Spring-charged type MDS-4SWA110 and breaker type NF400-SEW

Specifications		MDS.../MDSA...	MDS-4.../8...	MDS-16...
Breaker type ①	NF-S/H series	NF125-SGW / HGW NF160-SGW / HGW NF250-SGW / HGW	NF400-SEW / HEW / REW NF630-SEW / HEW / REW NF800-SEW / HEW / REW	NF1000-SEW NF1250-SEW NF1600-SEW
	NF-R/U series	NF125-RGW / UGW NF250-RGW / UGW	NF400-UEW, NF800-UEW	—
Rated operating voltage (V) (allowable voltage range 85–110%) ②		DC 24 V DC48–60V AC100–240V / DC100–250V	AC 100/110 V, 200/220 V (AC 240 V) DC 100/110 V (DC 125 V)	AC 100/110 V, 200/220 V (AC 240 V) DC 100/110 V (DC125 V)
Operating current (A, eff.) ③	DC	100 / 110 V	0.20	OFF: 1.0 (3.0) ON: 8.0
	AC	100 / 110 V	0.50	OFF: 1.0 (3.0) ON: 10.0
		200 / 200 V	0.35	OFF: 0.5 (1.5) ON: 8.0
Operating time (sec.)	ON operating	0.05–0.1 (self holding)	0.05	0.07
	OFF operating	0.6 and less (self holding)	3 and less (self holding)	3 and less (self holding)
	Spring charging	1.2 and less	—	—
Transformer capacity required (VA)		150	700	700
Endurance voltage (V)		1500	1500	1500

① Also usable for Disconnectors DSN with 3 and 4 poles.

② The voltages in parentheses () are special options and might require an external resistor. For details, consult your distributor.

③ The values in parentheses () show starting current.

General precautions for motor-operated electrical MCCBs

- The motor operated types should not be operated 10 times consecutively (one on/off counts as an operation).
- The operating voltage should be between 85 – 110 % of the rated control voltage.
- The current breaker position ON, OFF or TRIPPED will be shown with a special display on the motor.
- The dielectric strength of the electrical operating circuits is 1500 V. When performing a dielectric strength test simultaneously with another device at a voltage over 1500 V, the operating circuit terminal should be disconnected.

Automatic Reset

If the breaker is an auto reset type, it contains a built-in alarm switch and the off-control circuit close when the breaker is tripped. Since the breaker automatically resets itself after tripping, the power is easily restored by switching on the breaker again. With a UVT mounted, however, auto reset may not be possible. In this case, please consult your distributor.

- More details on request.

Spring-Charged Type MDS

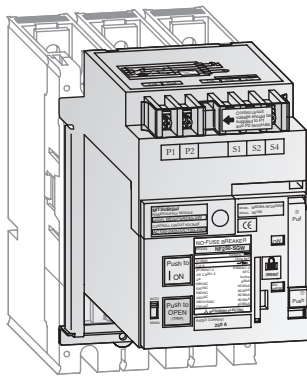

Spring-charged type MDS....-NF2GSWE and breaker type NF250-SGW

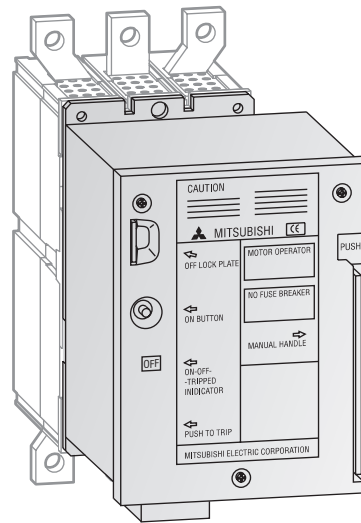

Spring-charged type MDS-4SW.... and breaker type NF400-SEW

Control circuit for MDS....-NF2GSWE

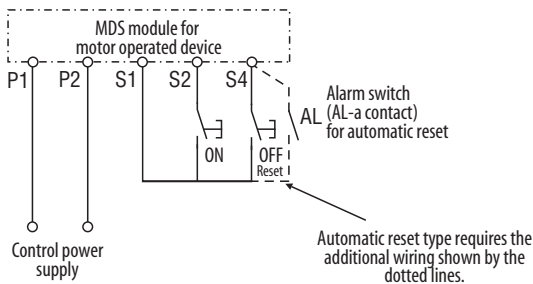

Control circuit for MDS-4/8/16 S....

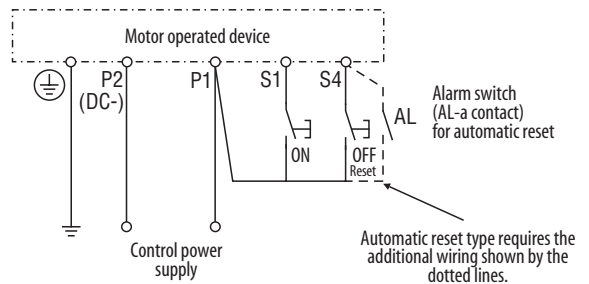

Spring-Charged Type

Electrical operation

When the ON switch is closed, the coil is releasing the latch mechanism, and the breaker is turned ON.

When the OFF switch is closed, a relay operates to start a motor which turns the breaker OFF (RESET) and charges the spring at the same time.

Manual operation

When the ON button (on the front of the spring-charged type) is pressed, the latch mechanism is cancelled and the circuit breaker set momentarily to ON by the force of spring.

OFF operation (RESET operation)

The circuit breaker can be set to OFF (RESET) by pressing the leaf spring, pulling out the manual handle and moving it back and forth more than ten times. This charges the spring at the same time.

Cautions during electrical operation

When an electrical-operation device is mounted in a breaker, this device must be returned to the discharged state after tripping of the breaker.

A MCCB with an electrical-operation device will not trip in the OFF state "PUSH TO TRIP" is used. This does not indicate that the breaker is faulty.

Since it takes 3 sec to switch off a breaker provided with this device, if the breaker needs to be opened urgently by remote control, a breaker fitted with an SHT or UVT should be used.

The breaker is equipped with a relay for the prevention of pumping.

Control circuit

For breakers with automatic resetting capability, add the connection indicated by the dotted line in the diagrams.

● More details on request.

Type	Breaker type	Rated voltage	Art. no.
MDS024-NF2GSWE	NF/DSN125-250	DC 24 V	139583
MDS060-NF2GSWE		DC48-60V	139584
MDSAD240-NF2GSWE		AC100-240V / DC100-250V	137514
MDS-4SWA110	NF/DSN400-630	AC 100-110 V	205968
MDS-4SWA240		AC 230 V	205969
MDS-4SWD110		DC 100-110 V	205970
MDS-8SWA110	NF/DSN800	DC 100-110 V	205971
MDS-8SWA240		AC 230 V	205972
MDS-8SWD110		DC 100-110 V	205973
MDS-16SSA110	NF/DSN1000-1600	AC 100-110 V	11463
MDS-16SSA220		AC 230 V	9430
MDS-16SSD110		DC 100-110 V	11464

Terminal Covers

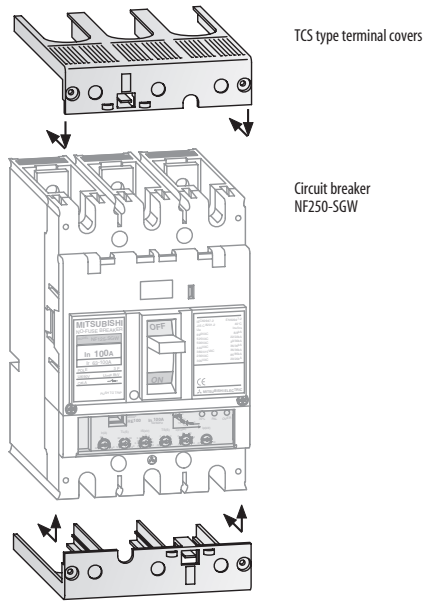

Application

The terminal covers are used to avoid exposure of charged parts.

Different types are available:

- for front connection as small terminal covers TCS or large terminal covers TCL, TTC (see figures below)
- for rear connection as closed type BTC
- for plug-in as PTC
- One set includes two pieces of terminal covers.
- Colour: black, white or transparent
- More types/details on request.

Small terminal covers TCS

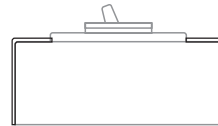

Large terminal covers TCL, TTC

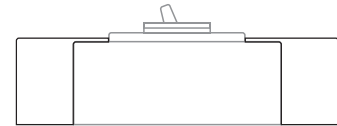

Small terminal covers TCS

(1 set = 2 pieces)

Type	No. of poles	Breaker type	Colour	Protection degree	Art. no.
TCS-05SW3W	3	NF/DSN32-63	white	IP20	146447
TCS-05SW4W	4				146448
TCS-2GSW3W	3	NF/DSN125-250	white	IP40	139605
TCS-2GSW4W	4				139606

Large terminal covers TCL

(1 set = 2 pieces)

Type	No. of poles	Breaker type	Colour	Protection degree	Art. no.
TCL-05SW3W	3	NF/DSN32-63	white	IP20	146445
TCL-05SW4W	4				146446
TCL-2GSW3W	3	NF/DSN125-250	white	IP40	139603
TCL-2GSW4W	4				139604
TCL-4SW3	3	NF/DSN400-630	black	IP20	205977
TCL-4SW4	4		transparent		205978
TCL-8SW3	3	NF/DSN800	transparent	IP20	205979
TCL-8SW4	4				205980
TCL-8UW3	3	NF/DSN800	transparent	IP20	205981
TCL-8UW4	4				205982
TCL-10SW3	3	NF/DSN1000-1250 (fixed with screws)	transparent	IP20	205983
TCL-10SW4	4				205984

Large terminal covers TTC

(1 set = 2 pieces)

Type	No. of poles	Breaker type	Colour	Protection degree	Art. no.
TTC-2GSW3	3	NF/DSN125-250	transparent	IP40	139611
TTC-2GSW4	4				139612

Terminal covers rear connection studs BTC

(1 set = 2 pieces)

Type	No. of poles	Breaker type	Colour	Protection degree	Art. no.
BTC-05SW3W	3	NF/DSN32-63	white	IP20	146449
BTC-05SW4W	4				146450
BTC-2GSW3W	3	NF/DSN125-250	white	IP40	139607
BTC-2GSW4W	4				139608
BTC-4SW3	3	NF/DSN400-630	transparent	IP20	205985
BTC-4SW4	4				205986
BTC-8SW3	3	NF/DSN800	transparent	IP20	205987
BTC-8SW4	4				205988

Terminal covers for 3-pole plug-in type PTC

(1 set = 2 pieces)

Type	No. of poles	Breaker type	Colour	Protection degree	Art. no.
PTC-05SW3W	3	NF/DSN32-63	white	IP20	146451
PTC-05SW4W	4				146452
PTC-2GSW3W	3	NF/DSN125-250	white	IP40	139609
PTC-2GSW4W	4				139610

Mechanical Interlock MI (Front)

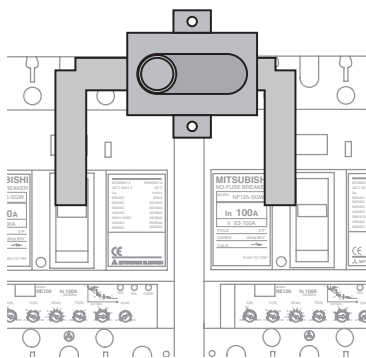

Application

With two breakers, use a panel-mounted mechanical interlock for one-way only input. It is usable for front, rear, and plug-in types.

A breaker-mounting mechanical to mount on the breaker main unit can be made to order.

● More details on request.

Mechanical interlocks for 3-pole breakers

Specifications	MI-05SW3	MI-4SW3	MI-8SW3	MI-10SW3	MI-16SW3
For use between two breakers of	125/160/250 AF	400 AF	630–800 AF	1000–1250 AF	1600 AF
Art. no.	139619	205989	205991	205993	205995

Mechanical interlocks for 4-pole breakers

Specifications	MI-2SW4	MI-4SW4	MI-8SW4	MI-10SW4	MI-16SW4
For use between two breakers of	125/160/250 AF	400 AF	630–800 AF	1000–1250 AF	1600 AF
Art. no.	139620	205990	205992	205994	205996

Isolation Barriers (Standard)

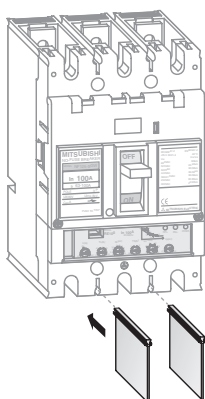

Application

The isolation barriers are used to avoid short-circuits between the terminals of the breaker due to dust or leakage current.

Every breaker is equipped with isolation barriers as standard.

IEC 35 mm Rail Mounting Adapter

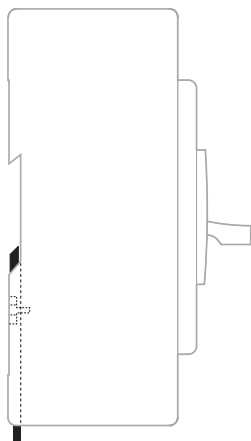

Application

The IEC 35 mm rail mounting adapter is used to mount the breaker on a IEC 35 mm mounting rail.

It is available for 3-pole breakers NF/DSN32–63.

Specifications	DIN-05SW
For 3-pole breakers	NF/DSN32–63
Art. no.	146459 (packing unit: 10 pcs)

■ **Tester for Electronic Breakers**

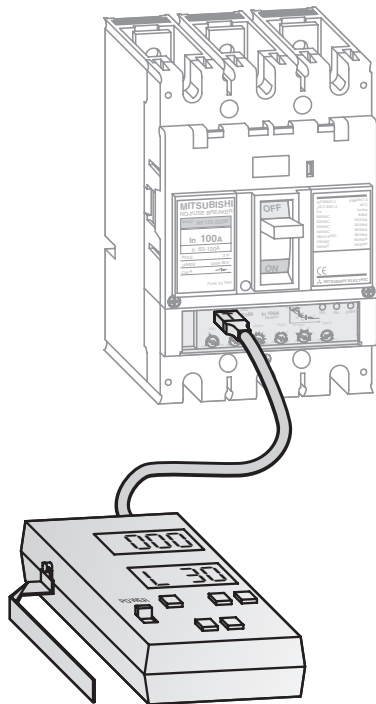

Application

The portable tester unit can be used to check the tripping characteristics of the electronic breakers from 100 A up to 1600 A.

Specifications	Y-250
for electronic breakers	100 A–1600 A
Art. no.	68181

Accessories

Alarm switch AL	26
Auxiliary switch AX	26
Handle lock devices	37
IEC 35 mm rail mounting adapter	41
Isolation barriers	41
Mechanical interlock MI	41
Motor operated devices MDS	39
Operating handle R-type	36
Operating handle V-type	36
Plug-in sets PM	35
Rear studs ST	35
Shunt trip device SHT	28
Solderless terminals SL	35
Terminal covers	40
Tester unit Y-250	42
Undervoltage tripping device UVT	30

Breaker specifications

Disconnectors	20
Moulded-case circuit breakers	12
Order information	22

Overviews and descriptions

Accessories for connection and installation	35
Breaker models	10
Internal accessories	24
Introduction & configuration	4
Motor operated breakers	38
Product skeleton of accessories	8

Software

MELSHORT2	7
---------------------	---

Global Partner. Local Friend.

EUROPEAN BRANCHES

MITSUBISHI ELECTRIC EUROPE B.V. 25, Boulevard des Bouvets F-92741 Nanterre Cedex Phone +33 1 55 68 55 68	FRANCE
MITSUBISHI ELECTRIC EUROPE B.V. Gothaer Straße 8 D-40880 Ratingen Phone +49 (0) 21 02/4 86-0	GERMANY
MITSUBISHI ELECTRIC EUROPE B.V. Westgate Business Park, Ballymount IRL-Dublin 24 Phone +353 (0)1 4198800	IRELAND
MITSUBISHI ELECTRIC EUROPE B.V. C.D. Colleoni - P.Sirio, Viale Colleoni 7 I-20041 Agrate Brianza (MI) Phone +39 (0) 39 60 53 1	ITALY
MITSUBISHI ELECTRIC EUROPE B.V. Carretera de Rubí 76-80 E-08190 Sant Cugat del Vallés (Barcelona) Phone +34 93 565 3131	SPAIN
MITSUBISHI ELECTRIC EUROPE B.V. Travellers Lane GB-Hatfield, Herts. AL10 8 XB Phone +44 (0) 1707/27 61 00	UK

EUROPEAN REPRESENTATIVES

GEVA Wiener Straße 89 AT-2500 Baden Phone +43 (0)2252 / 85 55 20	AUSTRIA	louis poulsen Geminivej 32 DK-2670 Greve Phone +45 (0)70 / 10 15 35	DENMARK	TEXEL Electronics Ltd Box 6272 IL-42160 Netanya Phone +972 (0)9 / 863 08 91	ISRAEL	Beijer Electronics AS Tejlværksveien 1 NO-3002 Drammen Phone +47 (0) 32 / 24 30 00	NORWAY	INEA SR d.o.o Karadjordjeva 12/260 113000 Smederevo Phone +381 (0)26 / 617 163	SERBIA	CSC Automation Ltd 15, M. Raskova St., Fl. 10, Office 1010 UA-02002 Kiev Phone +380 (0)44 / 494 3355	UKRAINE
TEHNIKON Oktyabrskaya 16/5, Off. 704 BY-220030 Minsk Phone +375 (0)17 / 2104626	BELARUS	UTU Elektrotehnika AS Pärnu mnt. 160i EE-11317 Tallinn Phone +372 (0)6 / 51 72 80	ESTONIA	Kazpromautomatiks Ltd. KAZAKHSTAN 2, Scladskaya str. KAZ-470046 Karaganda Phone +7 3212 50 11 50	KAZAKHSTAN	MPL Technology Sp.z o.o. ul. Krakowska 50 PL-32-083 Balice-Kraków Phone +48 (0)12 / 630 47 00	POLAND	AutoCont Control s.r.o. Radlinského 47 SK-02601 Dolný Kubín Phone +421 435868210	SLOVAKIA		
Koning & Hartman Woluwelaan 31 BE-1800 Vilvoorde Phone +32 (0)2 257 02 40	BELGIUM	Beijer Electronics OY Ansatie 6a FIN-01740 Vantaa Phone +358 (0)9 / 886 77 500	FINLAND	SIA POWEL Liens iela 28 LV-1009 Riga Phone +371 (0)784 / 2280	LATVIA	Sirius Trading & Services srl Str. Biharia nr. 67-77 RO-013981 Bucuresti 1 Phone +40 (0) 21 / 201 1146	ROMANIA	INEA d.o.o. Stegne 11 SI-1000 Ljubljana Phone +386 (0)1 / 513 8100	SLOVENIA		
AKHNATON 4 Andrej Ljapchev Blvd. Pb 21 BG-1756 Sofia Phone +359 (0)2 / 97 44 058	BULGARIA	UTECO A.B.E.E. S. Mavrogenous Str. GR-18542 Piraeus Phone +30 211 / 1206 900	GREECE	UAB UTU POWEL Savanoriu Pr. 187 LT-02300 Vilnius Phone +370 (0) 5 232 3101	LITHUANIA	ICOS Byazanskij Prospekt, 8A, Office 100 RU-109428 Moscow Phone +7 495 / 232 0207	RUSSIA	Beijer Electronics AB Box 426 S-20124 Malmö Phone +46 (0)40 / 35 86 00	SWEDEN		
INEA CR d.o.o. Losinjska 4 a HR-10000 Zagreb Phone +385 (0)1 / 36 940-01/-02/-03	CROATIA	Meltrade-Automatika Fertő utca 14 HU-1107 Budapest Phone +36 (0)1 / 431-9726	HUNGARY	INTEHISIS SRL bld. Traian 23/1 MD-2060 Kishinev Phone +36 (0) 22 / 66 4242	MOLDOVA	NPP URALLEKTRA Sverdlova 11A RU-620027 Ekaterinburg Phone +7 343 533 2745	RUSSIA	ECONOTEC AG Postfach 282 CH-8309 Nürensdorf Phone +41 44 / 838 48 11	SWITZERLAND		
AutoCont Jelinkova 59/3 CZ-721 00 Ostrava Svinov Phone +420 (0)59 / 5691 150	CZECH REPUBLIC	Ilan & Gavish Ltd 24 Shenkar St., Kiryat Arie IL-49001 Petah-Tiqva Phone +972 (0)3 / 922 18 24	ISRAEL	Koning & Hartman b.v. Haarlerbergweg 21-23 NL-1101 CH Amsterdam Phone +31 (0)20 / 587 76 00	NETHERLANDS	CRAFT Toplicna str.4 lok 6 1800 Nis Phone +381 (0)18 / 292-24-4/5	SERBIA	GTS Danulaceze Cad. No. 43 KAT.2 TR-34384 Okmeydanı-Istanbul Phone +90 (0) 212 / 320 1640	TURKEY	CBI Ltd Private Bag 2016 ZA-1600 Isando Phone +27 (0)11 / 928 2000	SOUTH AFRICA



Mitsubishi Electric Europe B.V. /// FA - European Business Group /// Gothaer Straße 8 /// D-40880 Ratingen /// Germany
Tel.: +49(0)2102-4860 /// Fax: +49(0)2102-486112 /// info@mitsubishi-automation.com /// www.mitsubishi-automation.com

Specifications subject to change /// Art. no. 133207-E /// 12.2007

Quick Reference Guide

Moulded-Case Circuit Breakers & Disconnectors



World Super Series

NF-S /// NF-H /// NF-R /// NF-U ///

Contents

Operation Characteristics

◆ NF30 – NF250.....	2
◆ NF400 – NF800	7
◆ NF1000 – NF1250.....	8

Dimensions

◆ NF/DSN32 – NF/DSN63.....	9
◆ NF/DSN125 – NF/DSN250.....	10
◆ NF/DSN400	12
◆ NF/DSN630.....	14
◆ NF/DSN800.....	16
◆ NF/DSN1000 – NF/DSN1250	17
◆ Accessories.....	19

More information?

This Quick Reference Guide is designed to give information about the operating characteristics and dimensions of moulded-cas circuit breakers of the World Super Series and related accessories. If you cannot find the information you require in this guide, there are a number of ways you can get further details on configuration and technical issues, pricing and availability.

For technical issues visit the www.mitsubishi-automation.com website.

Our website provides a simple and fast way of accessing further technical data and up to the minute details on our products and services. Manuals and catalogues are available in several different languages and can be downloaded for free.

For technical, configuration, pricing and availability issues contact our distributors and partners.

Mitsubishi partners and distributors are only too happy to help answer your technical questions or help with configuration building.

For a list of Mitsubishi partners please see the back of this catalogue or alternatively take a look at the “contact us” section of our website.

About this Quick Reference Guide

This Quick Reference Guide is a guide to the range of products available. For detailed configuration rules, system building, installation and configuration the associated product manuals must be read. You must satisfy yourself that any system you design with the products in this catalogue is fit for purpose, meets your requires and conforms to the product configuration rules as defined in the product manuals.

Specifications are subject to change without notice. All trademarks acknowledged.

■ Pre-alarm Characteristics

Operation characteristics

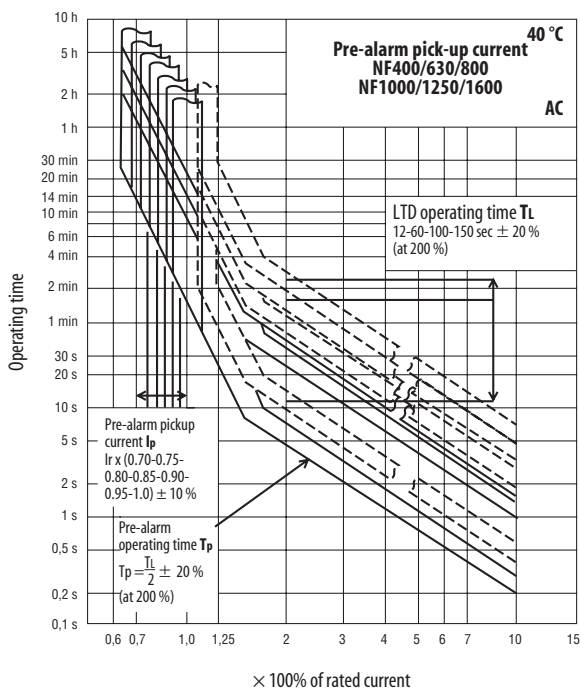
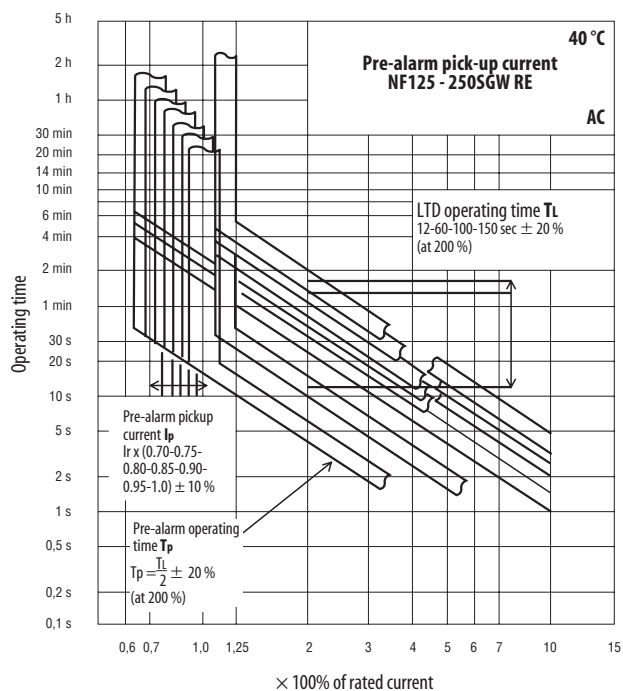

■ NF32-SW, NF63-SW, NF63-HW

Operation characteristics

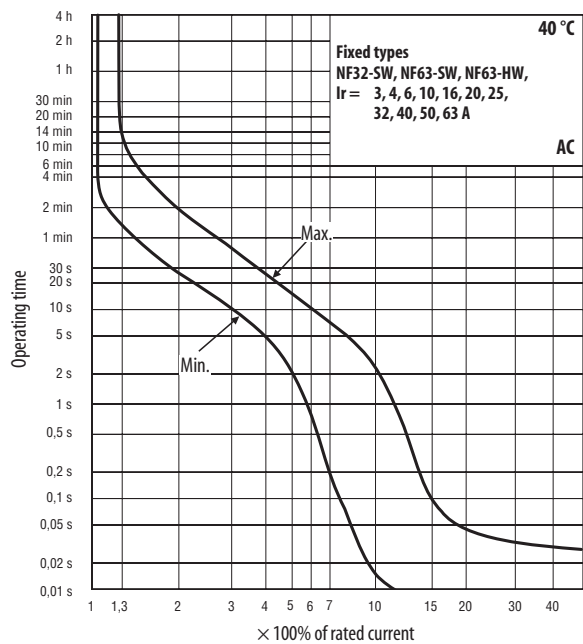

Temperature compensation characteristics

NF32-SW, NF63-SW, NF63-HW

Operating time change correction, regarding to rated ambient temperature

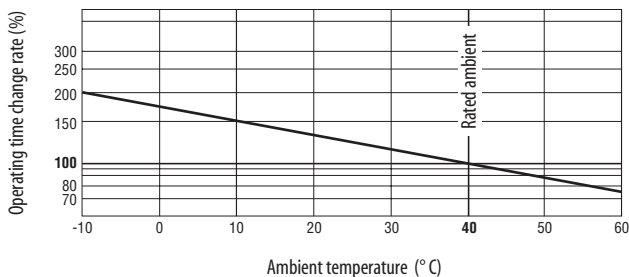

■ NF125-SGW RT, NF125-HGW RT, NF160-SGW RT, NF160-HGW RT, NF250-SGW RT, NF250-HGW RT

Operation characteristics

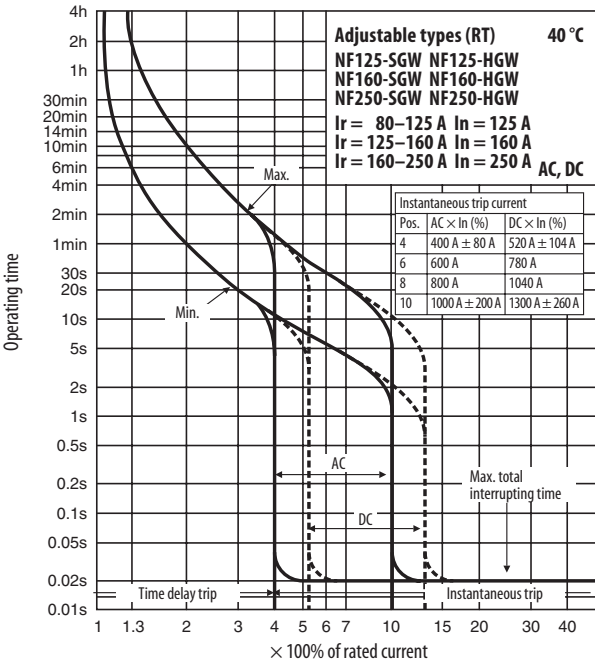
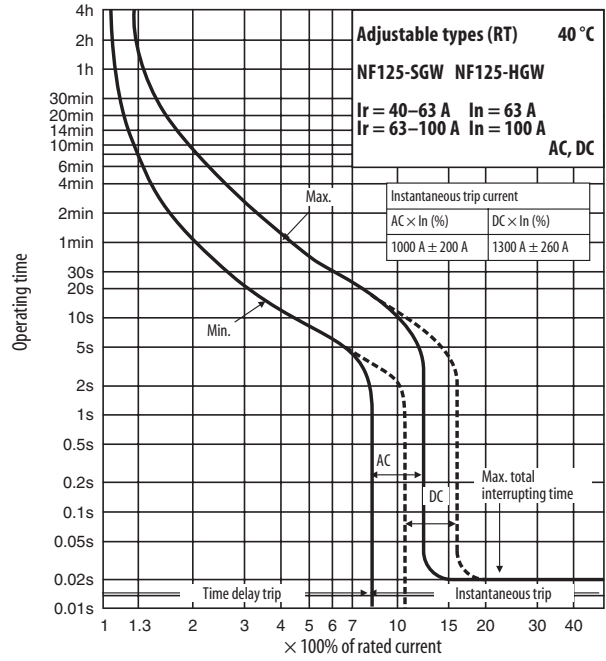
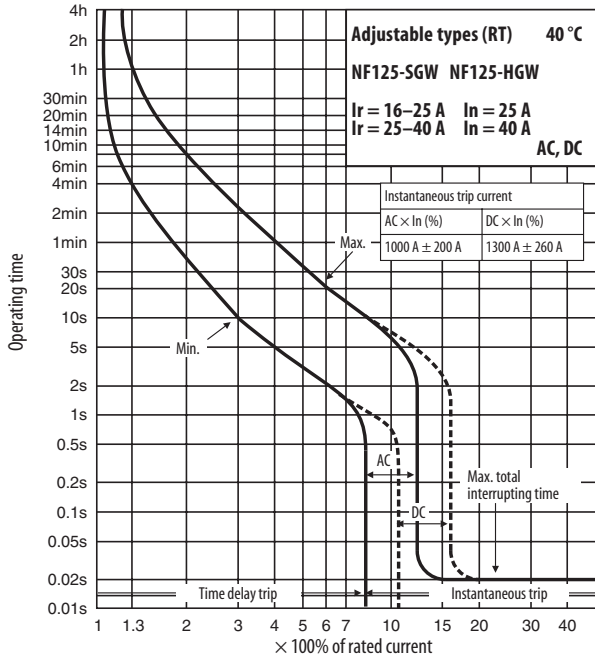

Temperature compensation characteristics

NF125-SGW RT, NF125-HGW RT,
 NF160-SGW RT, NF160-HGW RT,
 NF250-SGW RT, NF250-HGW RT

Current rating correction, regarding to rated ambient temperature

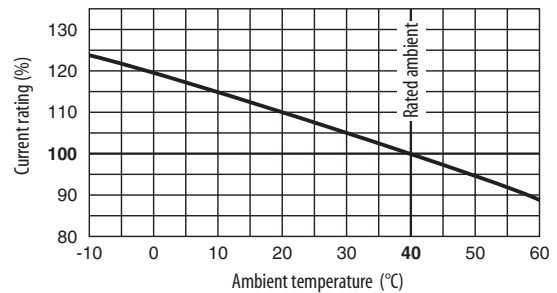

■ NF125-SGW RE, NF125-HGW RE, NF160-SGW RE, NF160-HGW RE, NF250-SGW RE, NF250-HGW RE

Operation characteristics

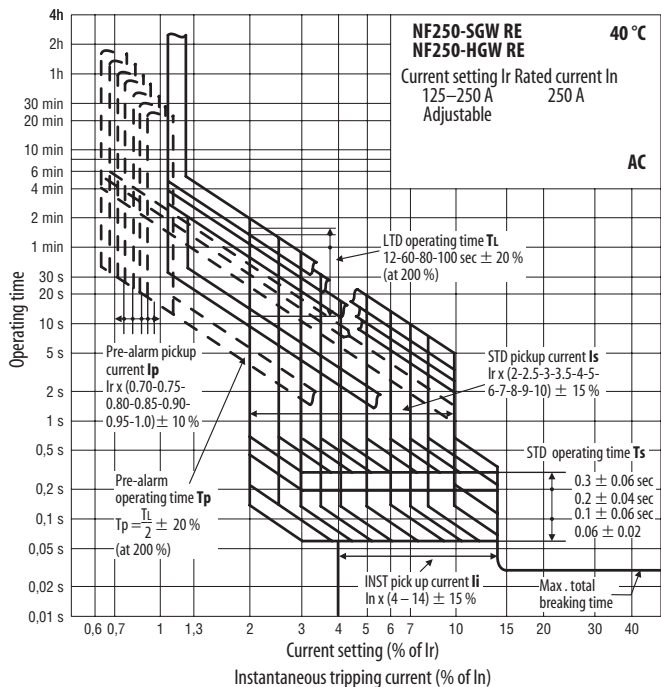
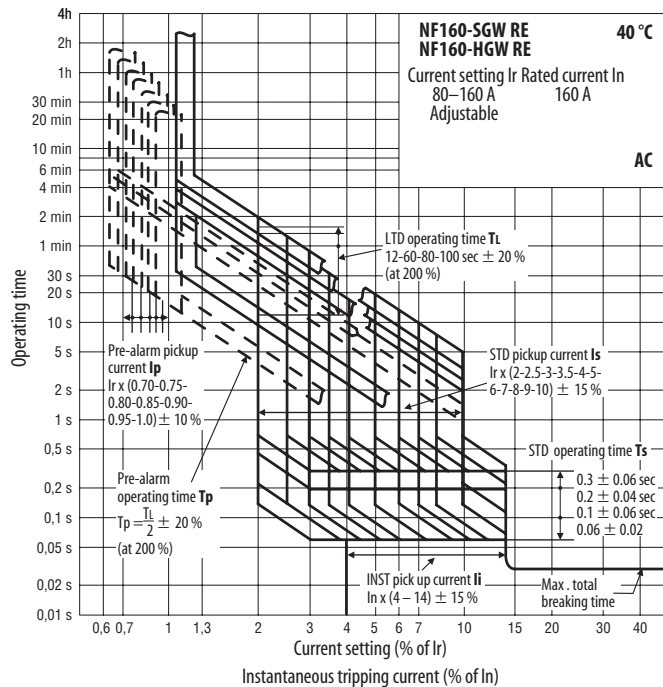
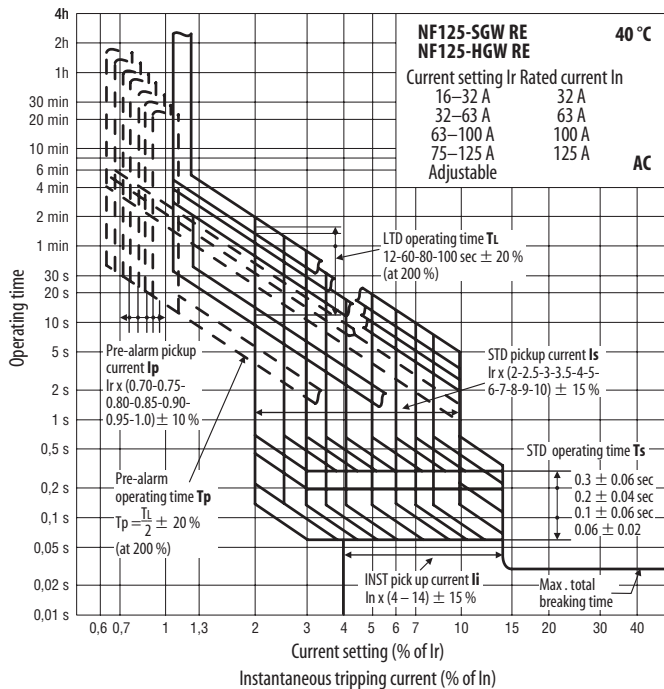

Temperature compensation characteristics

NF125-SGW RE, NF125-HGW RE,
NF160-SGW RE, NF160-HGW RE,
NF250-SGW RE, NF250-HGW RE

Current rating correction, regarding to rated ambient temperature

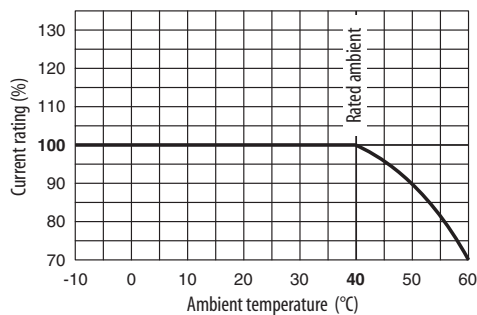

■ NF125-RGW RT, NF125-UGW RT, NF250-RGW RT, NF250-UGW RT

Operation characteristics

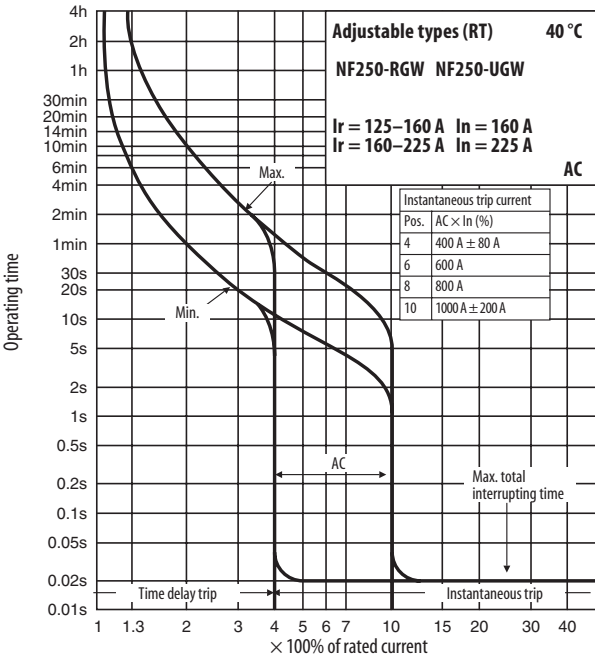
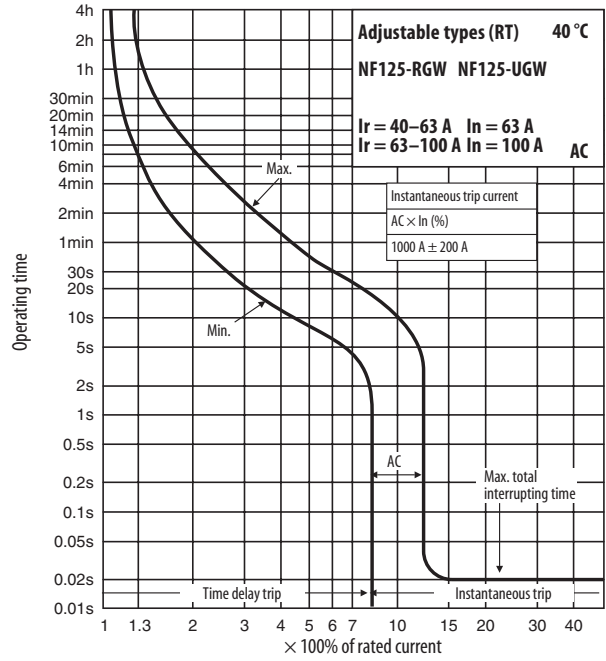
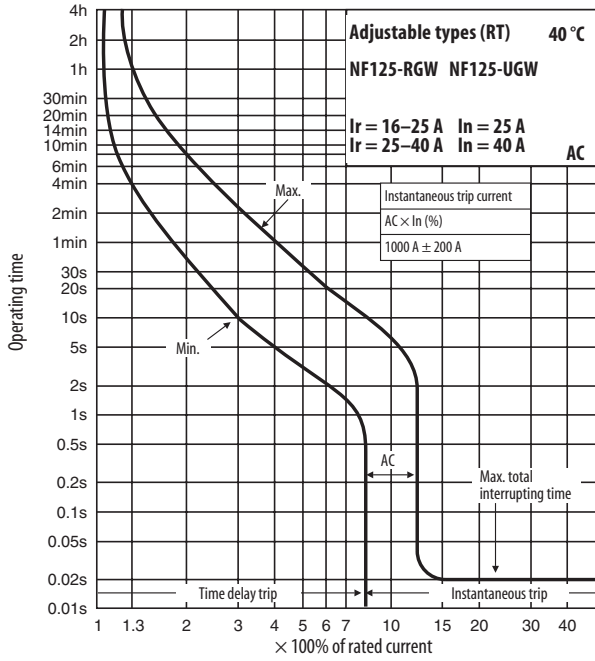

Temperature compensation characteristics

NF125-SGW RT, NF125-HGW RT,
 NF160-SGW RT, NF160-HGW RT,
 NF250-SGW RT, NF250-HGW RT

Current rating correction, regarding to rated ambient temperature

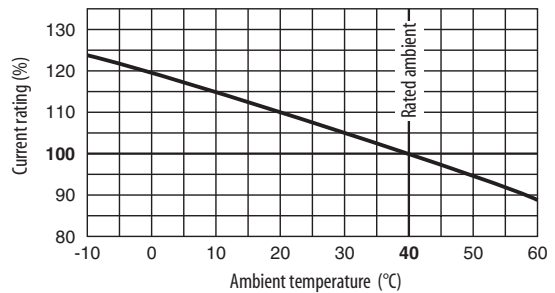

NF400-SEW/HEW/REW/UEW, NF630-SEW/HEW/REW, NF800-SEW/HEW/REW/UEW

Operation characteristics

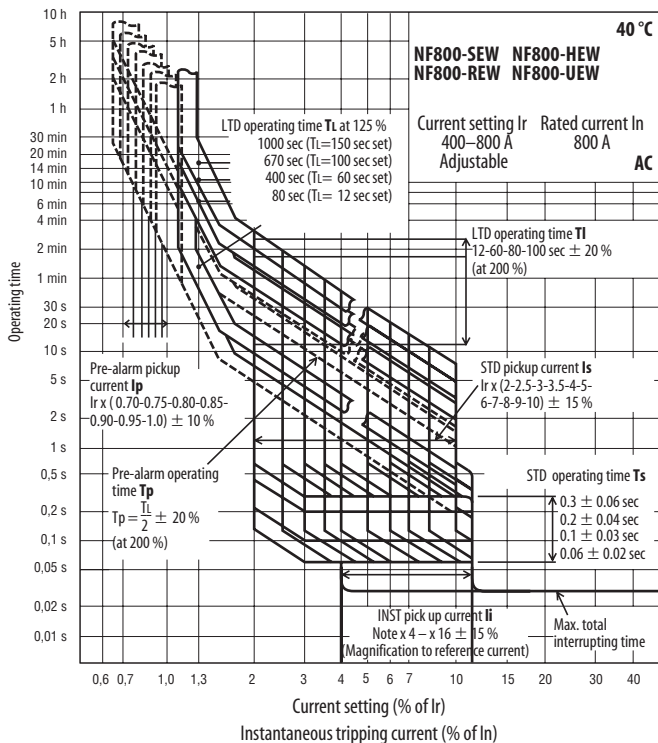
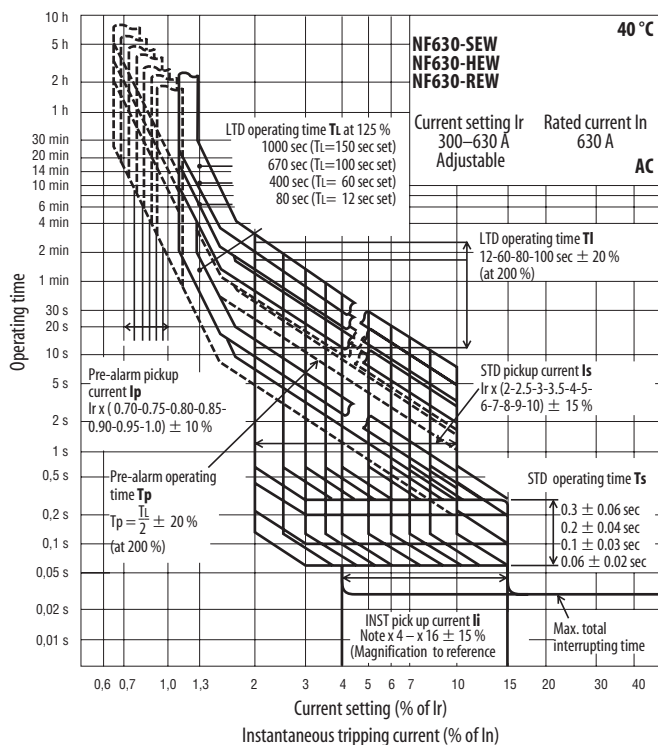
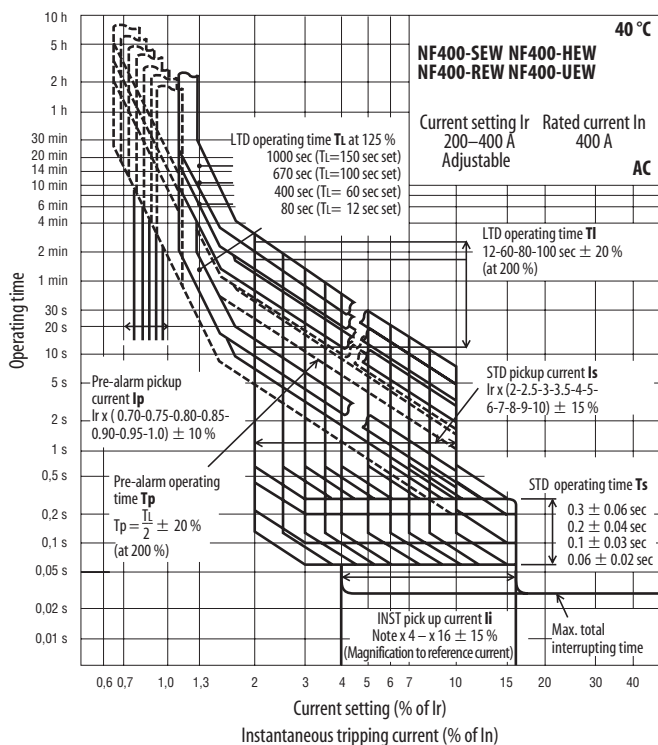

Temperature compensation characteristics

Current rating correction, regarding to rated ambient temperature

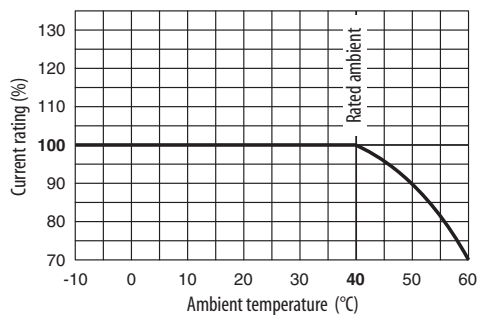

NF1000-SEW

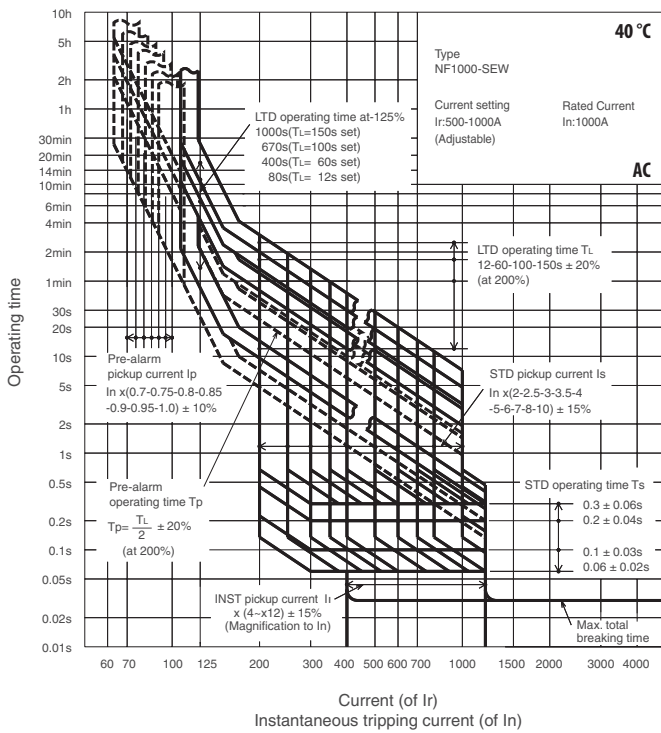

NF1250-SEW

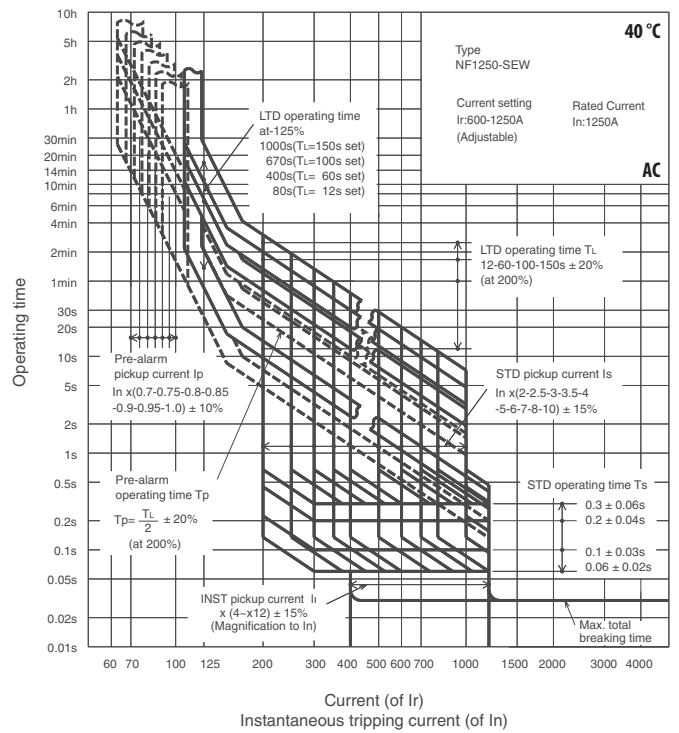

NF1600-SEW

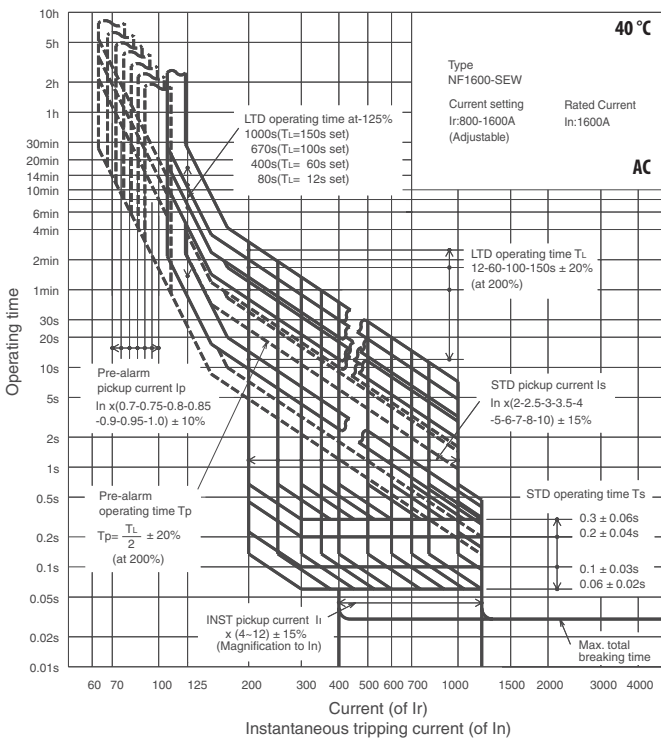

Temperature compensation characteristics

Current rating correction, regarding to rated ambient temperature

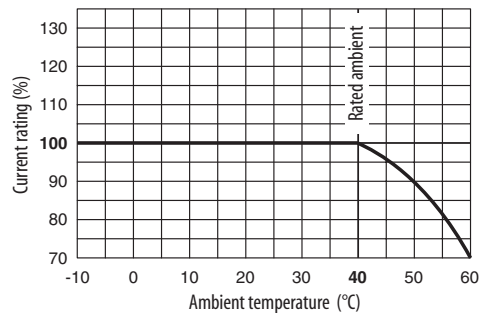

■ NF32-SW, NF63-SW, NF63-HW, DSN32-SW, DSN63-SW

Front connection

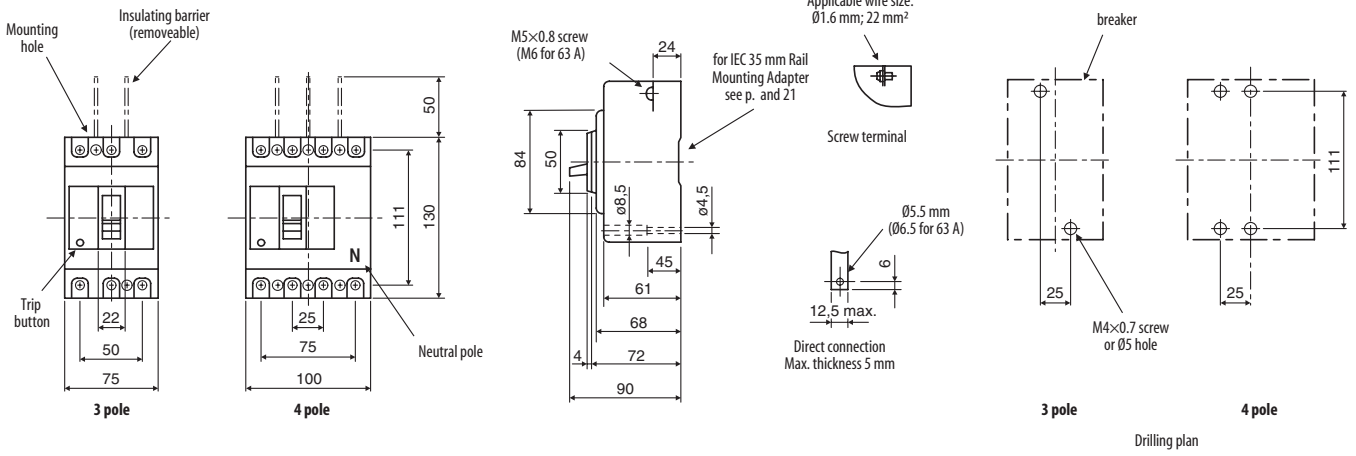

Rear connection

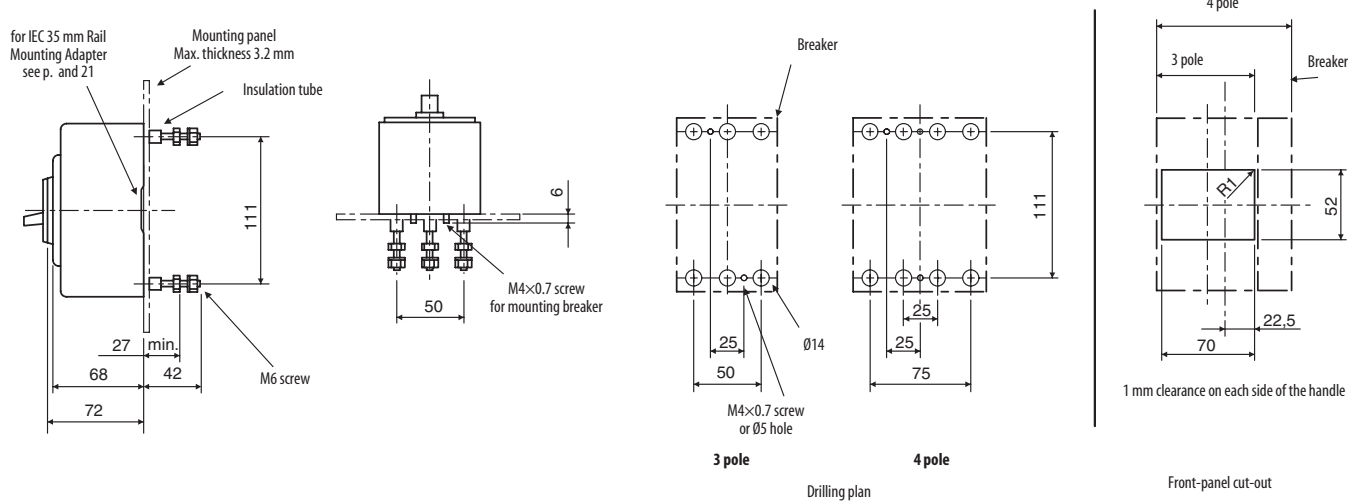

Plug-in

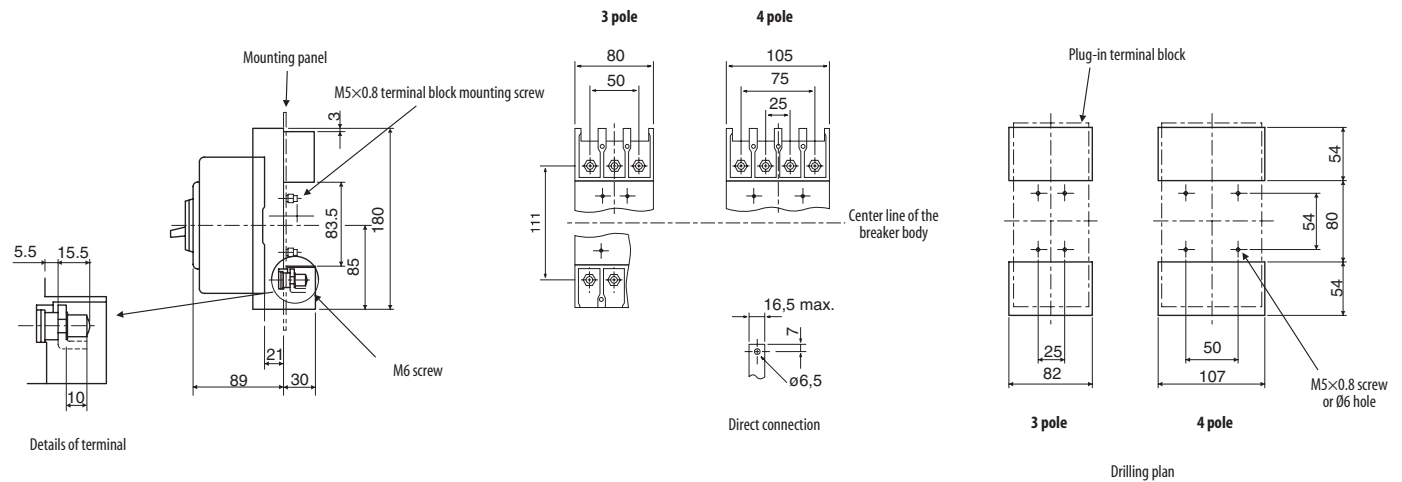

All dimensions in mm

■ NF400-SEW NF400-HEW, NF400-REW, DSN400-SW

Front connection

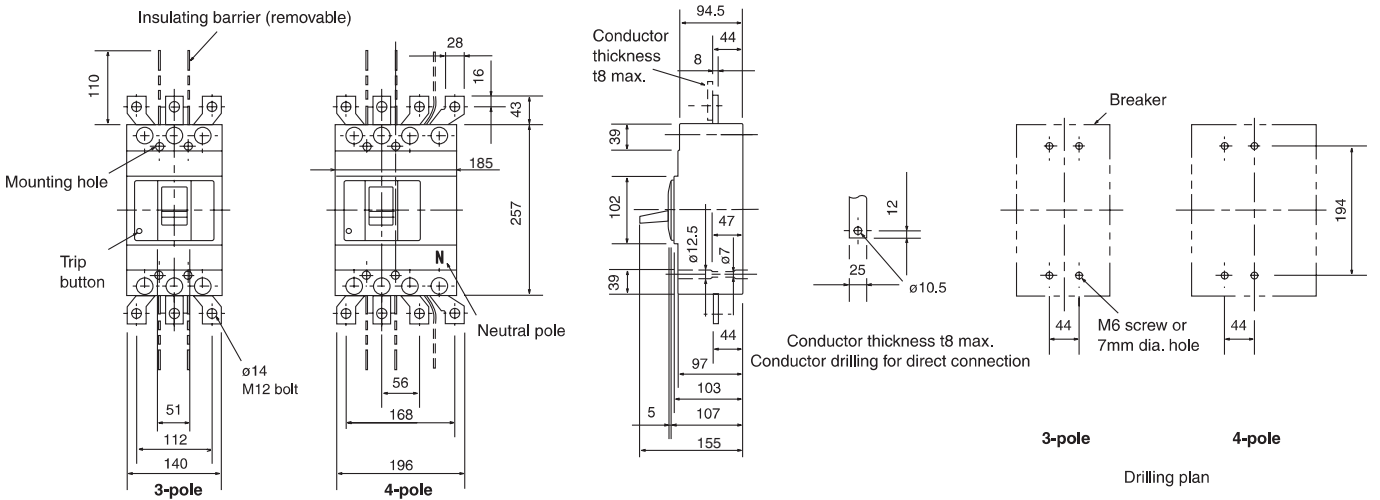

Front connection with mounted motor drive MDS

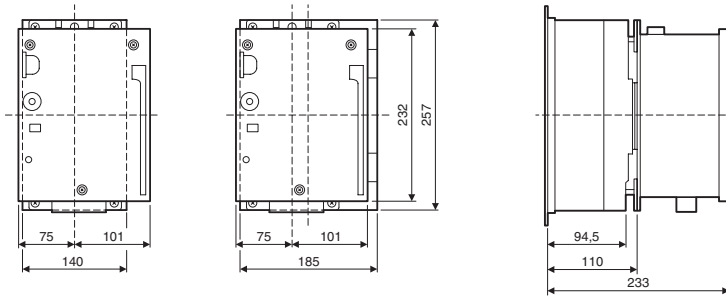

Rear connection

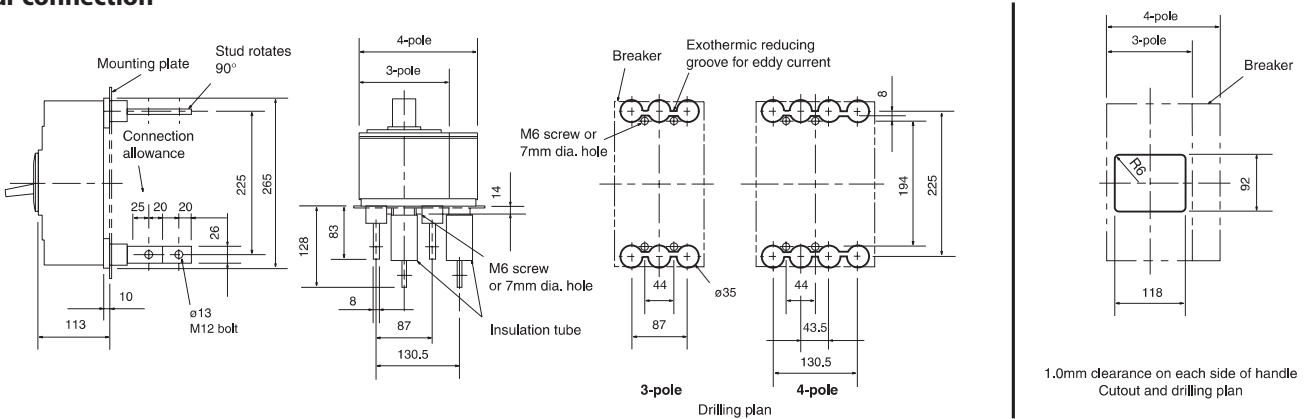

Plug-in

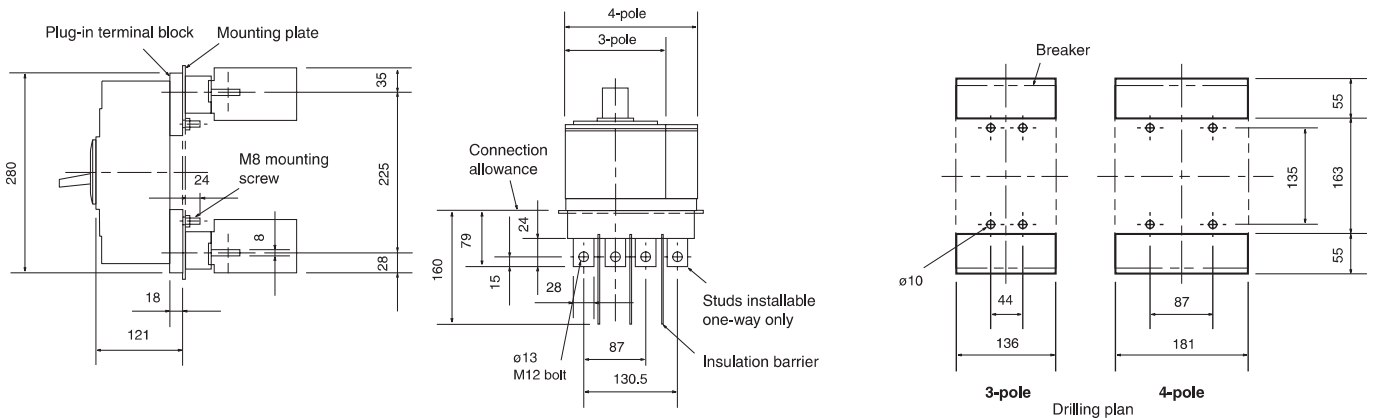

All dimensions in mm

■ NF400-U EW (3-pole type)

Remark: 4-pole type please see page 16.

Front connection

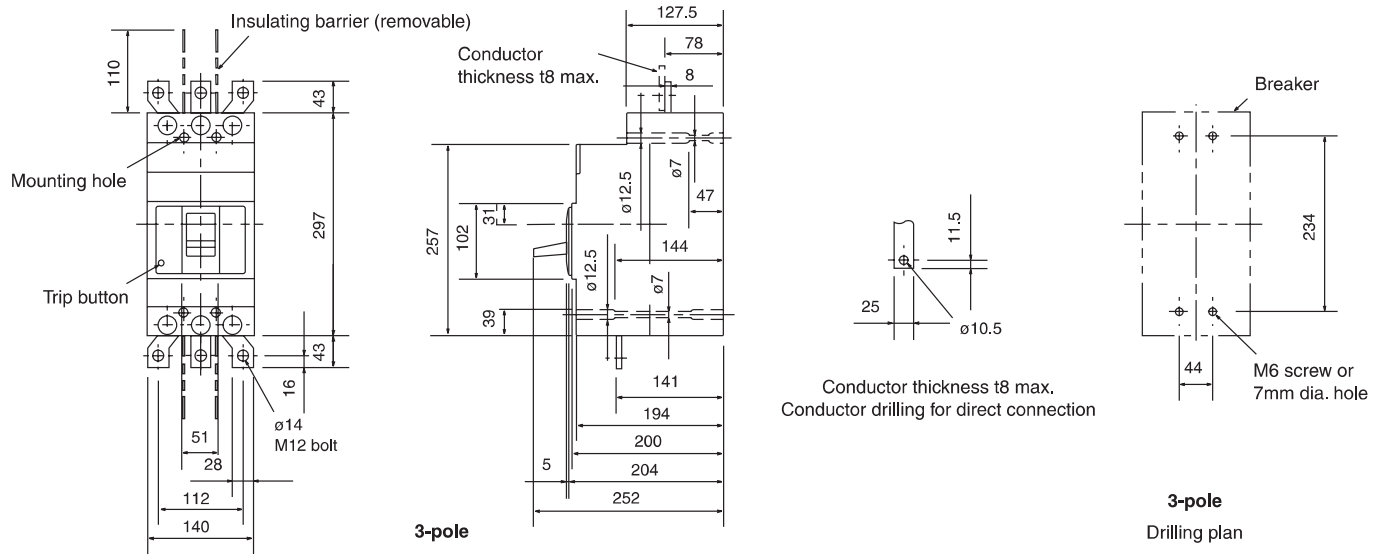

Rear connection

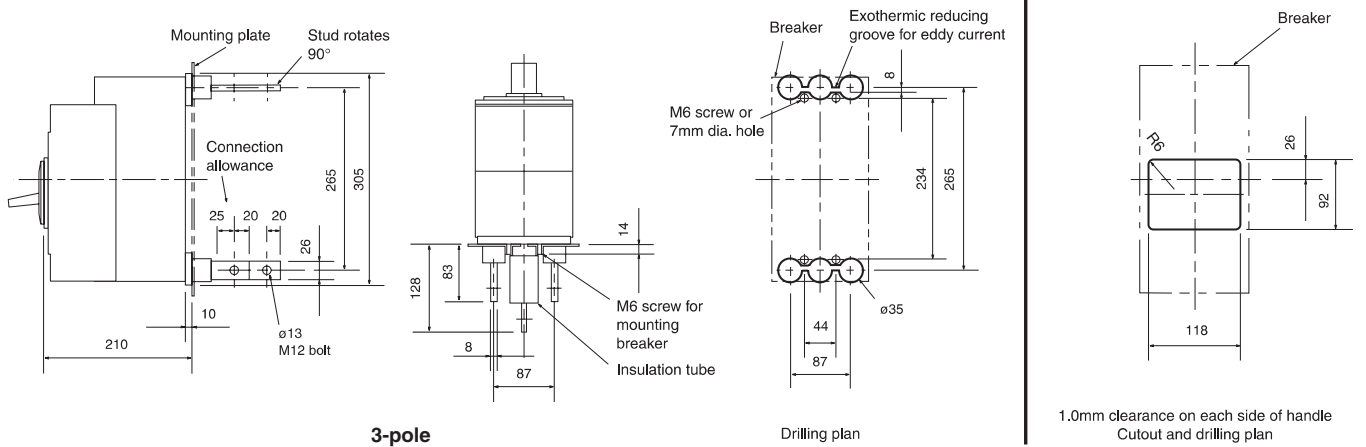

Plug-in

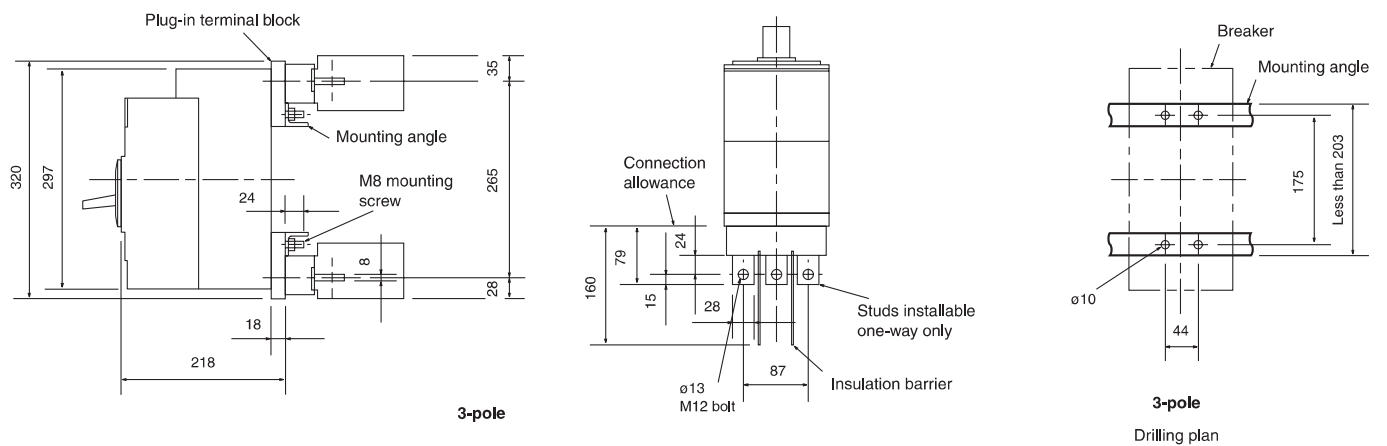

All dimensions in mm

■ NF630-SEW, NF630-HEW, NF630-REW, DSN630-SW

Front connection

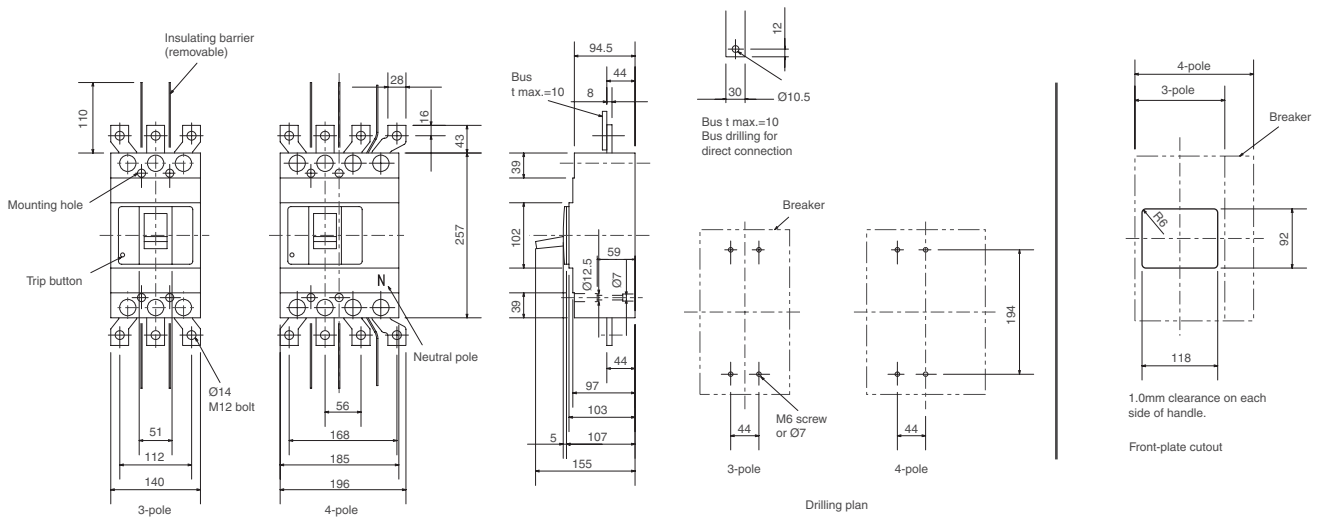

Rear connection

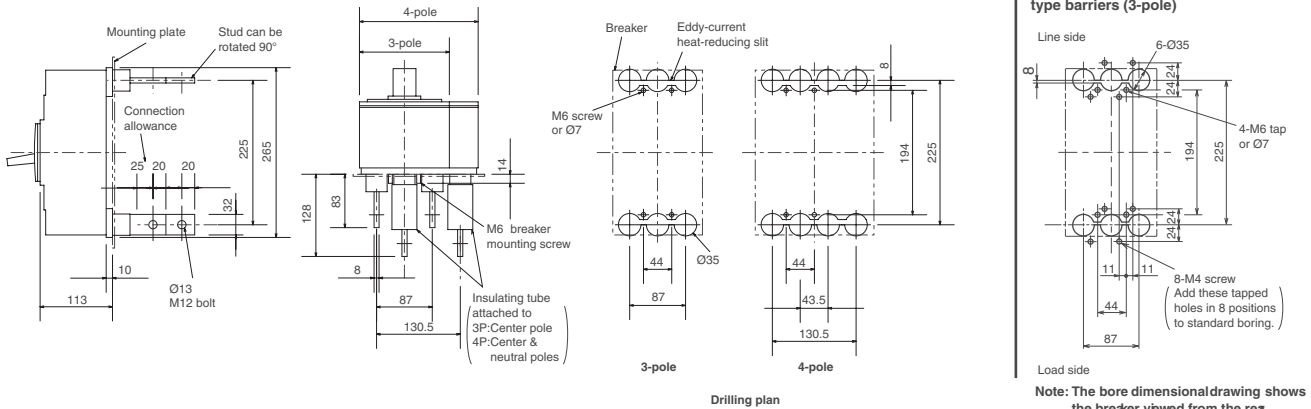

Plug-in

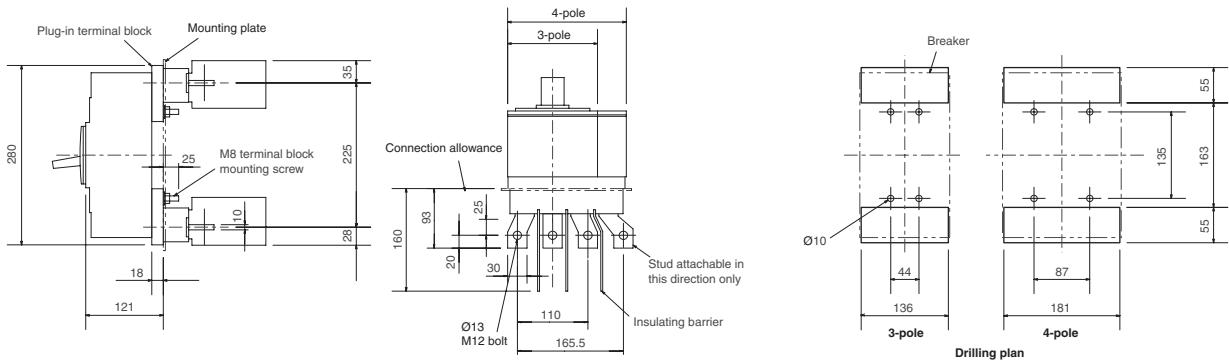

Front connection with mounted motor drive MDS

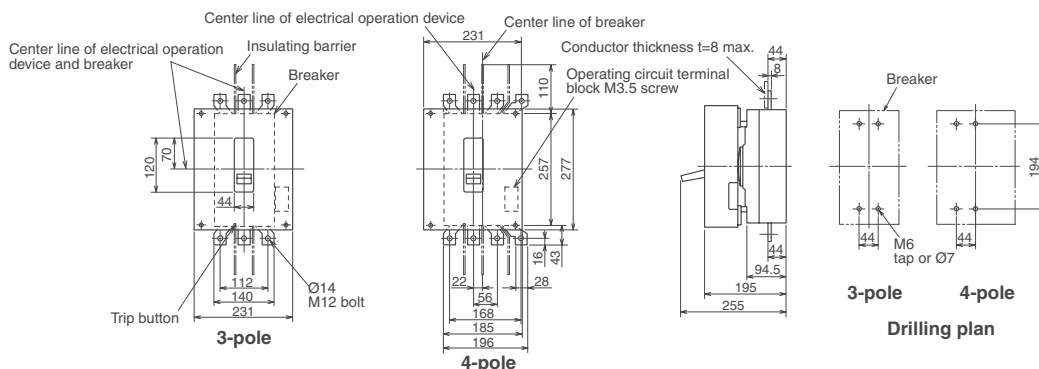

All dimensions in mm

■ NF800-SEW, NF800-HEW, NF800-REW, DSN800-SW

Front connection

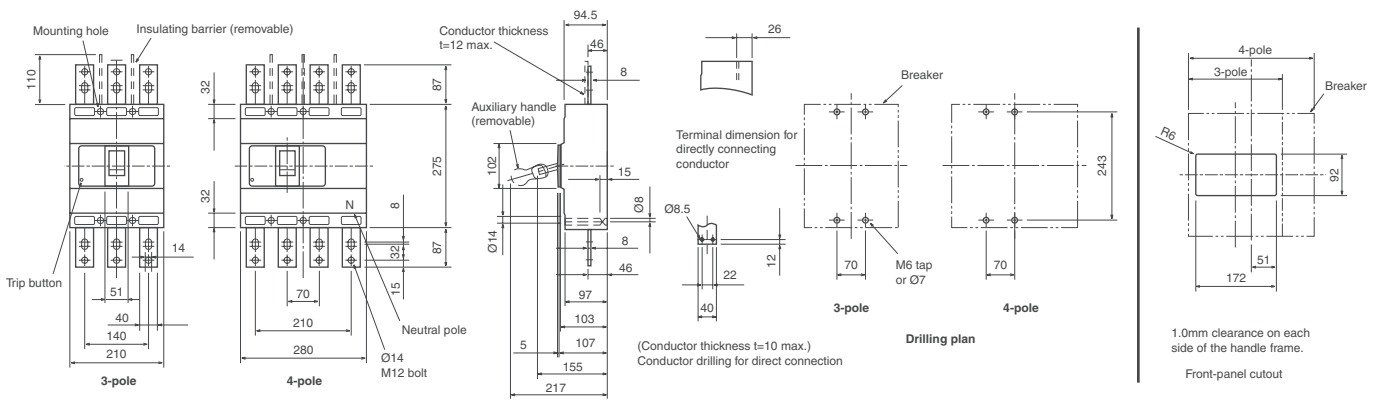

Rear connection

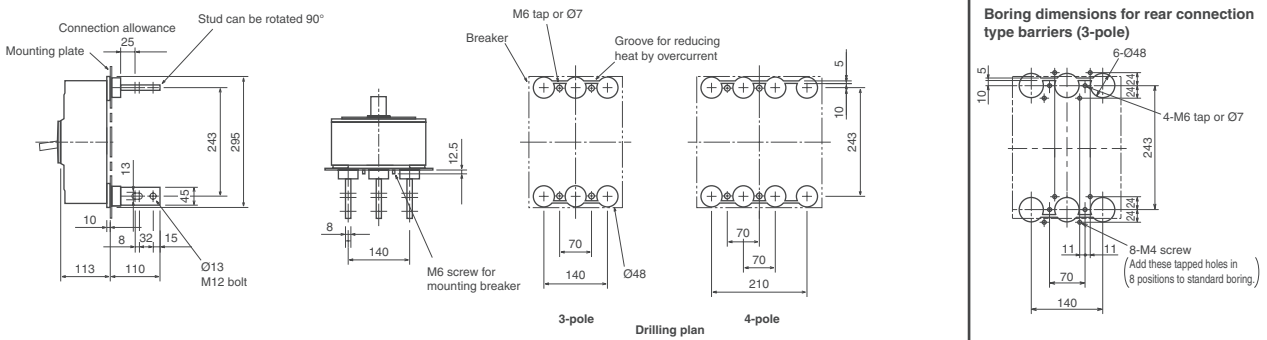

Plug-in

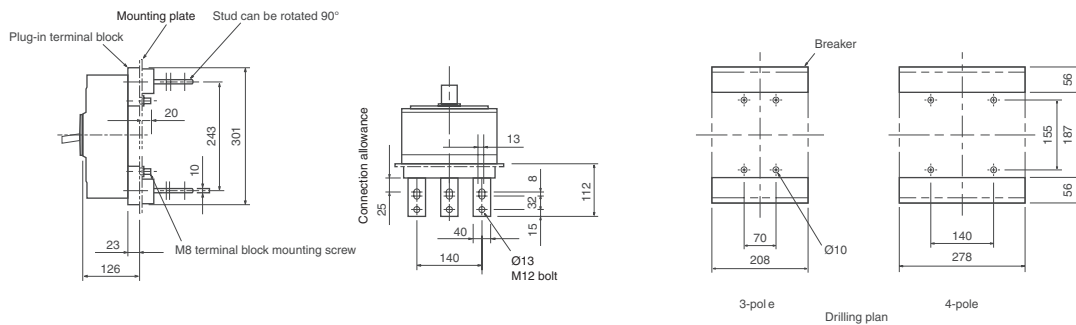

Front connection with mounted motor drive MDS

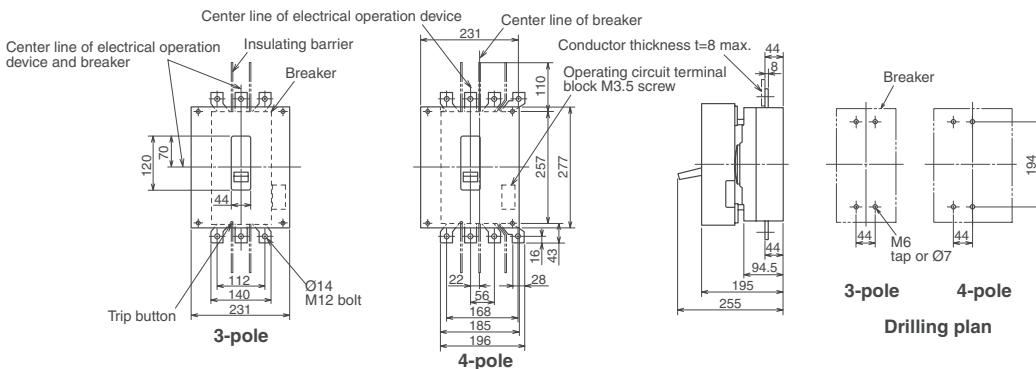

All dimensions in mm

■ NF1000-SEW, NF1250-SEW, DSN1000-SW, DSN1250-SW

Front connection

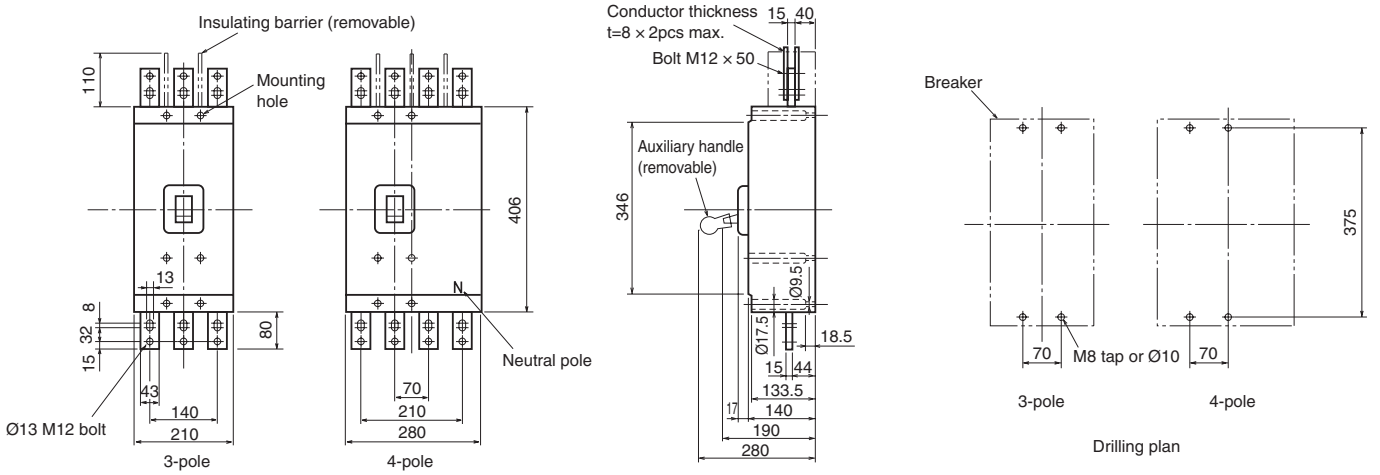

Rear connection

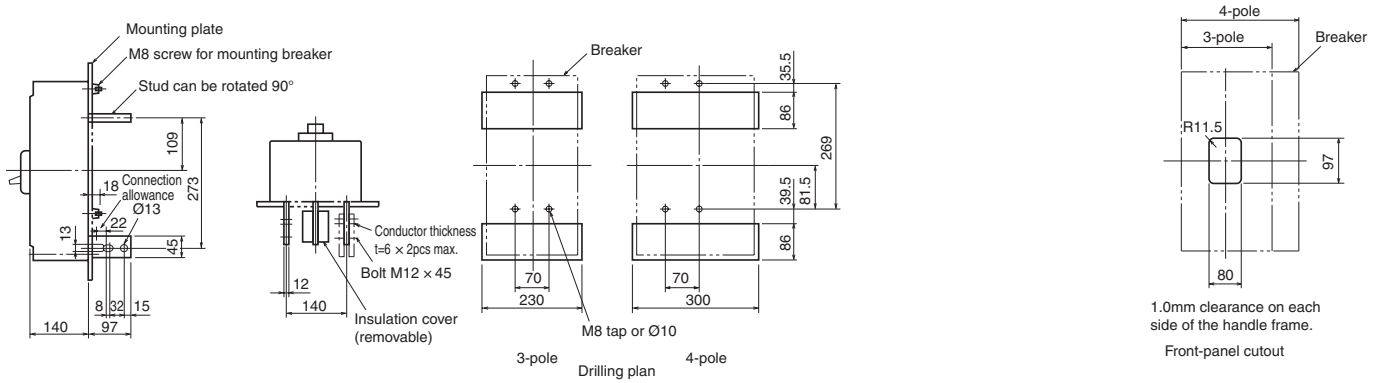

Plug-in

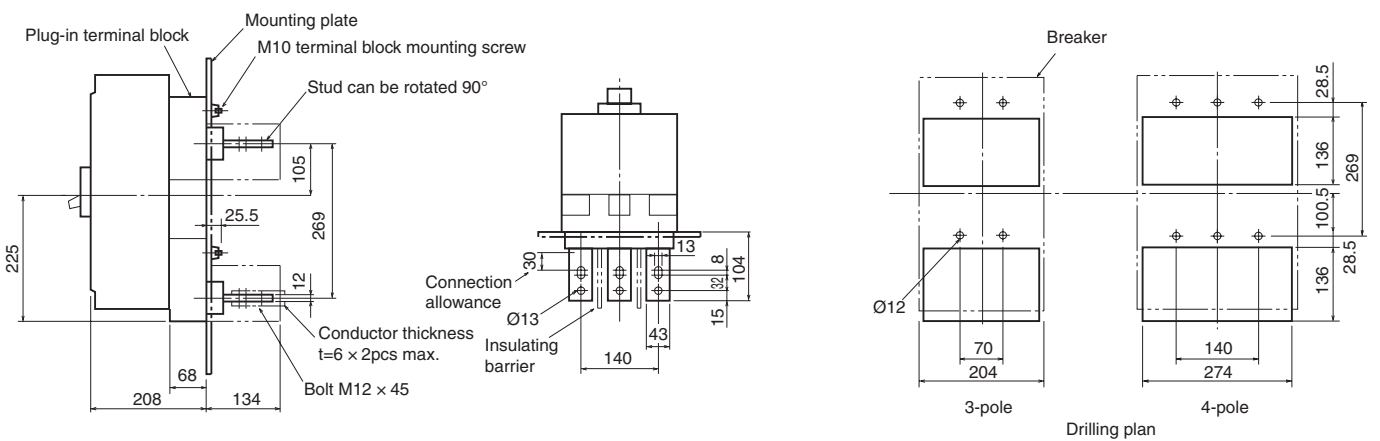

All dimensions in mm

■ Lead-Wire Terminal Block SLT

AL, AX, ALAX with 1 and 2 W (left-side mounted)
SHT (right-side mounted)

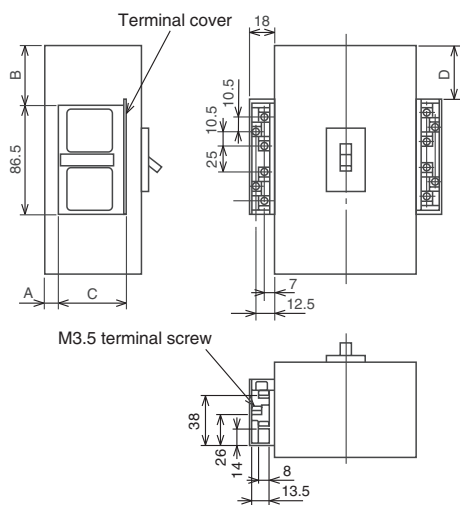

Dimensions for AL, AX, SHT and UVT

Breaker type	A	B	C	D
NF32-SW, NF63-SW/HW	7	17.5	54	17,5
NF125-SGW/HGW	25	25	54	19
NF125-RGW/UGW	25	100	54	95,5
NF160-SGW/HGW	25	25	54	20,5
NF250-SGW/HGW	25	25	54	20,5
NF250-RGW/UGW	25	100	54	95,5
NF400-SEW/HEW/REW NF630-SEW/HEW/REW	41	79.5	54	79,5
NF800-SEW/HEW/REW	41	88.5	54	88,5
NF1000-SEW NF1250-SEW NF1600-SEW	62.5	173	54	173
NF400-UEW (3 P)	138	119.5	54	119,5
NF400-UEW (4 P)	138	135.5	54	135,5

Tightening torque for terminal screws M3.5: 0.9–1.2 Nm
AL, AX and SHT are vertical lead-wire terminal block SHT.
UVT is horizontal lead-wire terminal block LT.

UVT (right-side mounted)

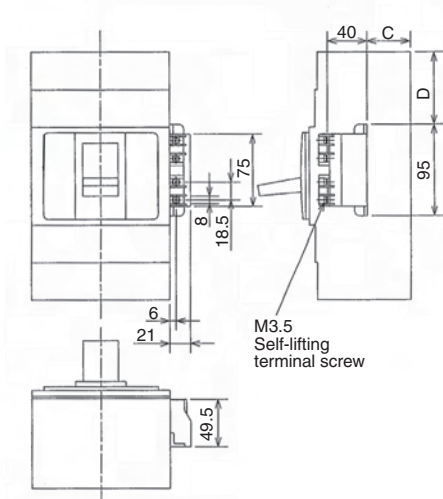

AL3, AX3, AX4, AL2AX2 with 3 and 4 W

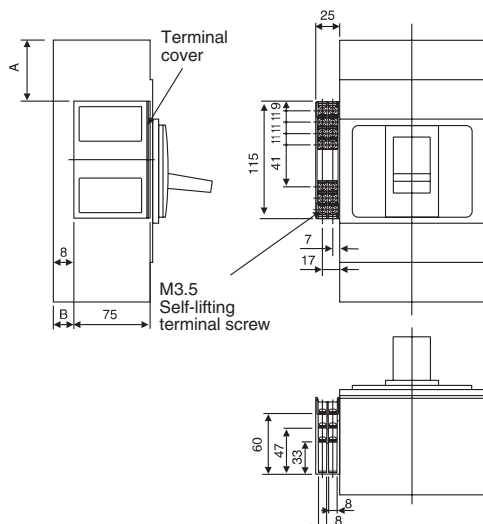

Dimensions for AL3, AX3, AX4, AL2AX2 with 3 and 4 W

Breaker type	A	B
NF400-SEW, NF630-SEW/HEW/REW	20	60
NF800-SEW/HEW/REW	20	69
NF1000-SEW, NF1250-SEW, SEW1600-SEW	117	100
NF400-UEW (3 P)	35	154
NF400-UEW (4 P)	117	116

Tightening torque for terminal screws M3.5: 0.9–1.2 Nm

All dimensions in mm

External Operating Handle – V Type

External dimensions

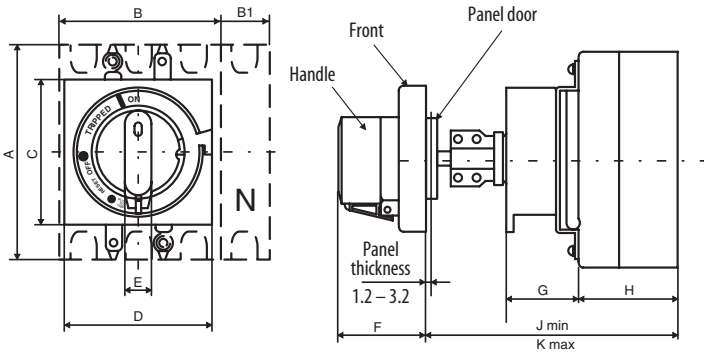

Drilling plan
NF32-250

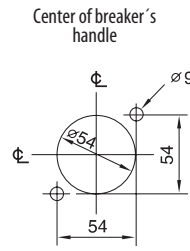

NF400-1600

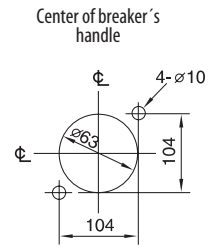

Type	Breaker type	Dimensions [mm]										
		A	B/B1	C	D	E	F	G	H	J	K	
V05SW(E)N	NF32-63	130	75/100	90	90	16	54	44	61	125	—	
V2SGW(E)N	NF125-250-SGW/HGW	165	105/140	90	90	16	54	46	79	172	536	
V2GUW(E)N	NF125/250-RGW/UGW	240	105/140	More details on request.								
V4SW(E)	NF400/630	257	140/196	140	140	25	62	76	97	217	539	
V8SW(E)	NF800	406	210/280	176	210	—	62	56	140	275	562	

More details on request.

External Operating Handle – R Type

External dimensions

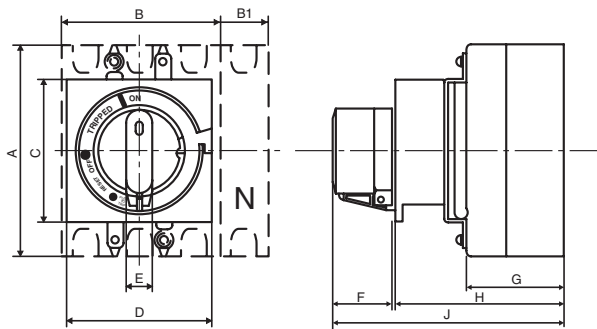

Type	Breaker type	Dimensions [mm]									
		A	B/B1	C	D	E	F	G	H	J	
R2GSW(E)N	NF125-250-SGW/HGW	165	105/140	88	88	16	37	79	125	162	
R2GUW(E)N	NF125/250-RGW/UGW	240	105/140	88	88	16	37	79	125	162	
R4SW(E)	NF400/630	257	140/196	128	140	25	43	97	174	218	
R8SW(E)	NF800	406	210/280	176	210	—	62	140	196	246	

More details on request.

■ Terminal Covers

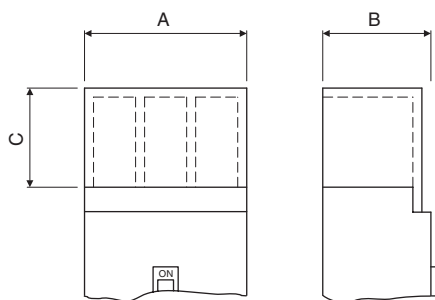

Small terminal covers TCS

Type	A	B	C
TCS-05SW3W	75	65.5	5
TCS-05SW4W	100	65.5	5
TCS-2GSW3W	105	84	6.5
TCS-2GSW4W	140	84	6.5

Large terminal covers TCL

Type	A	B	C
TCL-05SW3W	75	65.5	25
TCL-05SW4W	100	65.5	25
TCL-2GSW3W	105	84	40
TCL-2GSW4W	140	84	40
TCL-4SW3	171	99.5	110
TCL-4SW4	240	104.5	110
TCL-8SW3	224	103.5	155
TCL-8SW4	294	103.5	155
TCL-8UW3	220	146/194.5*	155
TCL-8UW4	290	146/194.5*	155
TCN-10SW3	220	139	150
TCN-10SW4	290	139	150

*Line side/load side

Large terminal covers TTC, transparent

Type	A	B	C
TTC-2GSW3	105	84	6.5
TTC-2GSW4	140	84	6.5

Terminal covers BTC

Type	A	B	C
BTC-05SW3W	75	65.5	5
BTC-05SW4W	100	65.5	5
BTC-2GSW3W	105	84	6.5
BTC-2GSW4W	140	84	6.5
BTC-4SW3	On request		
BTC-4SW4	On request		
BTC-8SW3	On request		
BTC-8SW4	On request		

Terminal covers PTC

Type	A	B	C
PTC-05SW3W	75	65.5	6.5
PTC-05SW4W	100	65.5	6.5
PTC-2GSW3W	105	84	6.5
PTC-2GSW4W	140	84	6.5

More details on request.

■ Adapter for IEC 35 mm Rail

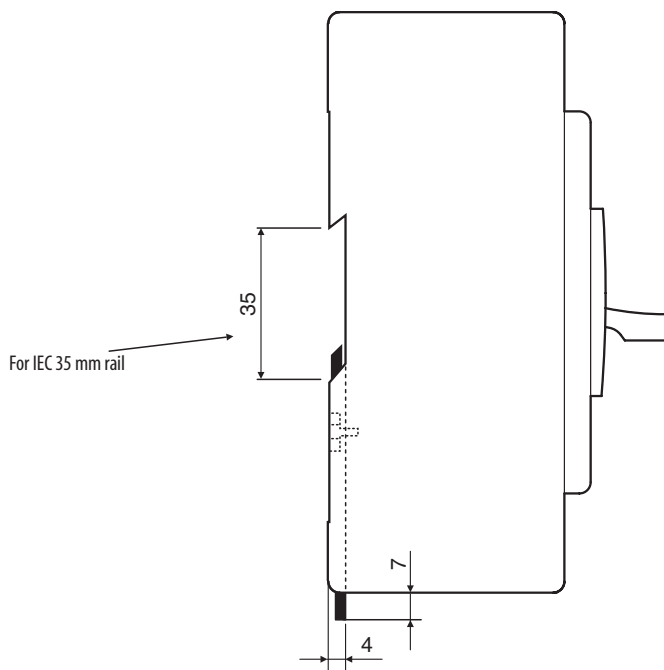

All dimensions in mm

Global Partner. Local Friend.

EUROPEAN BRANCHES

MITSUBISHI ELECTRIC EUROPE B.V. 25, Boulevard des Bouvets F-92741 Nanterre Cedex Phone +33 1 55 68 55 68	FRANCE
MITSUBISHI ELECTRIC EUROPE B.V. Gothaer Straße 8 D-40880 Ratingen Phone +49 (0) 21 02/4 86-0	GERMANY
MITSUBISHI ELECTRIC EUROPE B.V. Westgate Business Park, Ballymount IRL-Dublin 24 Phone +353 (0)1 4198800	IRELAND
MITSUBISHI ELECTRIC EUROPE B.V. C.D. Colleoni - P.Sirio, Viale Colleoni 7 I-20041 Agrate Brianza (MI) Phone +39 (0) 39 60 53 1	ITALY
MITSUBISHI ELECTRIC EUROPE B.V. Carretera de Rubí 76-80 E-08190 Sant Cugat del Vallés (Barcelona) Phone +34 93 565 3131	SPAIN
MITSUBISHI ELECTRIC EUROPE B.V. Travellers Lane GB-Hatfield, Herts. AL10 8 XB Phone +44 (0) 1707/27 61 00	UK

EUROPEAN REPRESENTATIVES

GEVA Wiener Straße 89 AT-2500 Baden Phone +43 (0)2252 / 85 55 20	AUSTRIA	louis poulsen Geminivej 32 DK-2670 Greve Phone +45 (0)70 / 10 15 35	DENMARK	TEXEL Electronics Ltd Box 6272 IL-42160 Netanya Phone +972 (0)9 / 863 08 91	ISRAEL	Beijer Electronics AS Teqverksveien 1 NO-3002 Drammen Phone +47 (0) 32 / 24 30 00	NORWAY	INEA SR d.o.o Karadjordjeva 12/260 SER-113000 Smederevo Phone +381 (0)26 / 617 163	SERBIA	CSC Automation Ltd 15, M. Raskova St., Fl. 10, Office 1010 UA-02002 Kiev Phone +380 (0)44 / 494 3355	UKRAINE
TEHNIKON Oktyabrskaya 16/5, Off. 704 BY-220030 Minsk Phone +375 (0)17 / 2104626	BELARUS	UTU Elektrotehnika AS Pärnu mnt. 160i EE-11317 Tallinn Phone +372 (0)6 / 51 72 80	ESTONIA	Kazpromautomatiks Ltd. KAZAKSTAN 2, Scladskaya str. KAZ-470046 Karaganda Phone +7 3212 50 11 50	KAZAKSTAN	MPL Technology Sp.z o.o. ul. Krakowska 50 PL-32-083 Balice-Kraków Phone +48 (0)12 / 630 47 00	POLAND	AutoCont Control s.r.o. Radlinského 47 SK-02601 Dolný Kubín Phone +421 435868210	SLOVAKIA		
Koning & Hartman Woluwelaan 31 BE-1800 Vilvoorde Phone +32 (0)2 257 02 40	BELGIUM	Beijer Electronics OY Ansatie 6a FIN-01740 Vantaa Phone +358 (0)9 / 886 77 500	FINLAND	SIA POWEL Liens iela 28 LV-1009 Riga Phone +371 (0)784 / 2280	LATVIA	Sirius Trading & Services srl Str. Biharia nr. 67-77 RO-013981 Bucuresti 1 Phone +40 (0) 21 / 201 1146	ROMANIA	INEA d.o.o. Stegne 11 SI-1000 Ljubljana Phone +386 (0)1 / 513 8100	SLOVENIA		
AKHNATON 4 Andrej Ljapchev Blvd. Pb 21 BG-1756 Sofia Phone +359 (0)2 / 97 44 058	BULGARIA	UTECO A.B.E.E. S. Mavrogenous Str. GR-18542 Piraeus Phone +30 211 / 1206 900	GREECE	UAB UTU POWEL Savanoriu Pr. 187 LT-02300 Vilnius Phone +370 (0) 5 232 3101	LITHUANIA	ICOS Byazanskij Prospekt, 8A, Office 100 RU-109428 Moscow Phone +7 495 / 232 0207	RUSSIA	Beijer Electronics AB Box 426 S-20124 Malmö Phone +46 (0)40 / 35 86 00	SWEDEN		
INEA CR d.o.o. Losinjska 4 a HR-10000 Zagreb Phone +385 (0)1 / 36 940-01/-02/-03	CROATIA	Meltrade-Automatika Fertő utca 14 HU-1107 Budapest Phone +36 (0)1 / 431-9726	HUNGARY	INTEHISIS SRL bld. Traian 23/1 MD-2060 Kishinev Phone +36 (0) 22 / 66 4242	MOLDOVA	NPP URALLEKTRA Sverdlova 11A RU-620027 Ekaterinburg Phone +7 343 533 2745	RUSSIA	ECONOTEC AG Postfach 282 CH-8309 Nürensdorf Phone +41 44 / 838 48 11	SWITZERLAND		
AutoCont Jelinkova 59/3 CZ-721 00 Ostrava Svinov Phone +420 (0)59 / 5691 150	CZECH REPUBLIC	ilan & Gavish Ltd 24 Shenkar St., Kiryat Arie IL-49001 Petah-Tiqva Phone +972 (0)3 / 922 18 24	ISRAEL	Koning & Hartman b.v. Haarlerbergweg 21-23 NL-1101 CH Amsterdam Phone +31 (0)20 / 587 76 00	NETHERLANDS	CRAFT Toplicna str.4 lok 6 SER-1800 Nis Phone +381 (0)18 / 292-24-4/5	SERBIA	GTS Danulazce Cad. No. 43 KAT.2 TR-34384 Okmeydanı-Istanbul Phone +90 (0) 212 / 320 1640	TURKEY	CBI Ltd Private Bag 2016 ZA-1600 Isando Phone +27 (0)11 / 928 2000	SOUTH AFRICA



Mitsubishi Electric Europe B.V. /// FA - European Business Group /// Gothaer Straße 8 /// D-40880 Ratingen /// Germany
Tel.: +49(0)2102-4860 /// Fax: +49(0)2102-486112 /// info@mitsubishi-automation.com /// www.mitsubishi-automation.com

Specifications subject to change /// Art. no. XXXXXX-A /// 02.2008